

Sanitary Hose Assembly Products

Meet Sanitary Standards with our Custom Solutions



Seal-Rite™ Permanent Crimp

Rubber
PVC
Silicone
Teflon/PTFE Lined
Stainless Braided



ReSeal® Reusable Couplers

Rubber
PVC
Silicone
Teflon/PTFE Lined

Choosing your Sanitary Hose

Selecting the right sanitary hose for your specific application is critical for optimal performance and provides the following benefits:

Saves Money

- Maximizes the life of your hose assembly.
- Availability of reusable couplers.

Ensures Process Integrity & Reliability

- Eliminates premature hose failure due to incompatibility with cleaning chemicals.
- Increases process efficiency by minimizing production problems and potential downtime due to incorrect hose incompatibility with processing application.

Maintains Quality Standards

- Ensures sanitary certifications to meet regulatory requirements while providing the highest levels of process integrity and product quality.

Providing the “stamped” information below will assist our hose experts in identifying and configuring the appropriate hose for your specific application.

S	Size <i>(Inner Diameter and Length)</i>
T	Temperature <i>(Working and Cleaning)</i>
A	Application <i>(Location and Purpose)</i>
M	Media <i>(Products and CIP Chemicals)</i>
P	Pressure <i>(Working and Cleaning)</i>
E	End Style <i>(Type and Size Alignment)</i>
D	Delivery <i>(Special Packaging)</i>

Contents

Seal-Rite™ Permanent Crimp

See Blue Section Pages 3-14

A patented 3-A radial crimp design provides an economical and reliable choice for permanent crimped hose assemblies. Correctly specified and properly cared for hoses will result in longer life.



ReSeal® Reusable Coupler

See Red Section Pages 15-21

Crushing, excessive dragging and abuse can prematurely wear hoses. A slightly higher initial investment in reusable ends will reap future savings when replacing the hose and reusing the stainless couplers.



Accessories

See Page 22

Hose supports help increase longevity of your hose

Fitting Sizing Chart

See Page 23

Find the right size for your Sanitary Clamp Fitting

Seal-Rite™ Permanent Radial Crimp Fittings

Seal-Rite radial crimp couplers are the purest unitized assemblies available today. Our external crimp design provides a 360° fixed seal at the coupler stem to hose junction point that eliminates the possibility of product wicking between the hose and coupler. Unlike internal expansion which can deform metal and yield die impressions, radial crimp technology will not interfere with the internal surface of the coupling stem. A full flow smooth bore transition is created after fabrication that excludes ledges or crevices that can collect bacteria.

TwistLOC™ components become a single unit that resist separation under severe applications. Internal surface finishes exceed 15 Ra. Each coupling stem is manufactured from 316L grade stainless steel and stamped with a material traceability number which is our commitment to quality. Seal-Rite radial crimped couplers are available for attachment on a variety of hoses. A wide range of end styles, sizes ¾" through 6" are available.

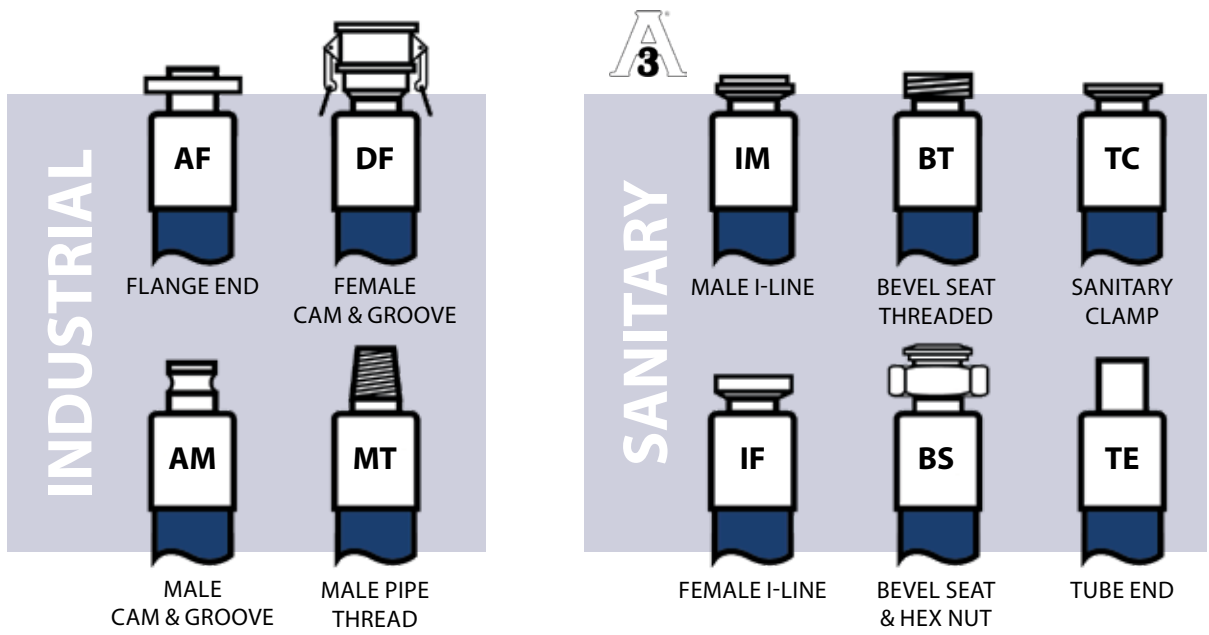
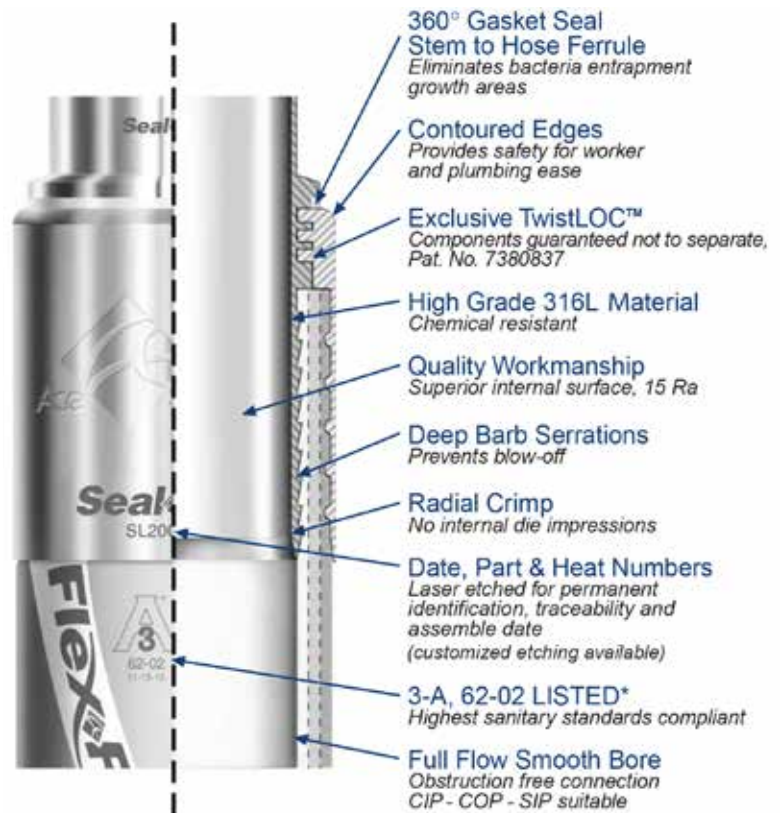

Rubber Hose

RSD Flex-Rite™ Suction & Discharge Hose



- Tube:** White Chlorobutyl
- Cover:** Gray, Red & Blue EPDM w/ White Stripe
- Reinforcement:** Spiral-plied synthetic fabric w/ dual wire helix
- Color:** RSD - Gray, all sizes.
RSDR - Red, 1.5", 2", 3" only
RSDB - Blue, 1.5", 2", 3" only
- Temp. Range:** -40° to 225°F
- Max. Length:** 100'
- Approvals:** 3-A*, FDA, USDA

Superb quality and versatility make this hose an ideal choice in food and dairy plants for both product transfer and CIP applications. The dual wire helix gives it extra flexibility making it easier to handle, and the specially compounded tube works to not impart taste or odor and is highly resistant to common CIP solutions. With multiple color options, this hose allows you to differentiate applications, which is especially helpful when dealing with allergens and other color-coding.

Stock #	Model	ID	OD	Working Pressure	Min. Bend Radius	Vacuum in HG.	Weight Per Ft.
113-2005	RSD050	0.5"	1.00"	150 psi	2.0"	29"	0.32-lbs
113-2007	RSD075	0.75"	1.25"	150 psi	2.0"	29"	0.57-lbs
113-2010	RSD100	1"	1.50"	150 psi	3.0"	29"	0.91-lbs
113-2015	RSD150	1.5"	2.06"	150 psi	4.0"	29"	1.03-lbs
113-2020	RSD200	2"	2.57"	150 psi	4.5"	29"	1.32-lbs
113-2025	RSD250	2.5"	3.12"	150 psi	5.5"	29"	1.84-lbs
113-2030	RSD300	3"	3.74"	150 psi	7.0"	29"	2.55-lbs
113-2040	RSD400	4"	4.77"	150 psi	10.0"	29"	5.51-lbs
113-2060	RSD600	6"	6.75"	150 psi	22.0"	29"	5.42-lbs
113-2018	RSDR150	1.5"	2.06"	150 psi	4.0"	29"	1.03-lbs
113-2023	RSDR200	2"	2.57"	150 psi	4.5"	29"	1.32-lbs
113-2033	RSDR300	3"	3.74"	150 psi	7.0"	29"	2.55-lbs
113-2019	RSDB150	1.5"	2.06"	150 psi	4.0"	29"	1.03-lbs
113-2024	RSDB200	2"	2.57"	150 psi	4.5"	29"	1.32-lbs
113-2034	RSDB300	3"	3.74"	150 psi	7.0"	29"	2.55-lbs

PSD Saint Gobain Suction & Discharge Hose



- Tube:** White Chlorobutyl
- Cover:** Light Gray or White EPDM
- Reinforcement:** Two fabric spirals w/ helix wire
- Color:** PSD - Gray, all sizes
PSDW - White, 1.5", 2", 3" only
- Temp. Range:** -40° to 225°F
- Max. Length:** 100'
- Approvals:** 3-A*, FDA, USDA, CFIA

High-quality and versatile hose that is ideal for transporting many food plant applications. The smooth inner lining works to not impart taste or odor to your product and is highly resistant to common CIP solutions, plus the abrasion resistant cover helps maintain a clean appearance.

Stock #	Model	ID	OD	Working Pressure	Min. Bend Radius	Vacuum in HG.	Weight Per Ft.
671-2505	PSD050	0.5"	1.03"	150 psi	2.0"	29"	0.40-lbs
671-2507	PSD075	0.75"	1.25"	150 psi	3.0"	29"	0.56-lbs
671-2510	PSD100	1"	1.53"	150 psi	4.0"	29"	0.65-lbs
671-2515	PSD150	1.5"	2.16"	150 psi	6.0"	29"	1.07-lbs
671-2520	PSD200	2"	2.66"	150 psi	7.0"	29"	1.43-lbs
671-2525	PSD250	2.5"	3.19"	150 psi	8.0"	29"	2.08-lbs
671-2530	PSD300	3"	3.75"	150 psi	9.0"	29"	2.63-lbs
671-2540	PSD400	4"	4.75"	150 psi	12.0"	29"	3.14-lbs
671-2518	PSDW150	1.5"	2.16"	150 psi	6.0"	29"	1.07-lbs
671-2523	PSDW200	2"	2.66"	150 psi	7.0"	29"	1.53-lbs
671-2533	PSDW300	3"	3.75"	150 psi	9.0"	29"	2.63-lbs

*3-A 62-02 standard applies only to assemblies of 3/4" diameter and larger.

WARNING: Working pressure ratings are based on ambient temperature. Working pressure and vacuum ratings will decrease as temperatures increase.

Rubber Hose

XFR Saint Gobain Suction & Discharge Hose



Tube:	White Bromobutyl
Cover:	Blue Thermoplastic w/ White Stripe
Reinforcement:	316L stainless steel wire helix, synthetic plies
Color:	Blue
Temp. Range:	-40° to 248°F
Max. Length:	130'
Approvals:	3-A, FDA

Durable, lightweight, and extra flexible hose, suitable for various food processing applications. The inner tube reduces the risk of flavor contamination and is compatible with many types of food products such as beer, wine, and milk. With a lower weight per foot than traditional suction and discharge hoses, this hose is easy to bend and attach to most pumps and tanks.

Stock #	Model	ID	OD	Working Pressure	Min. Bend Radius	Vacuum in HG.	Weight Per Ft.
671-3010	XFR100	1"	1.46"	150 psi	2.8"	26"	0.57-lbs
671-3015	XFR150	1.5"	2.00"	150 psi	3.2"	26"	0.75-lbs
671-3020	XFR200	2"	2.52"	150 psi	3.9"	26"	0.99-lbs
671-3030	XFR300	3"	3.62"	150 psi	5.9"	26"	1.68-lbs

REB ExtremeFlex™ Beverage Hose



Tube:	White Chlorobutyl
Cover:	Red Corrugated EZ Clean UHMWPE
Reinforcement:	Spiral-plied fabrics w/ double steel wire helix
Color:	Red
Temp. Range:	-30° to 220°F
Max. Length:	100'
Approvals:	3-A, FDA

Ideal for applications that require flexibility and tight bend connections. These hoses are well suited for milk, beer, wine, distillery, beverage and other edible liquid transfer in a processing plant. The microbe-resistant inner lining works to not impart taste or smell onto your products.

Stock #	Model	ID	OD	Working Pressure	Min. Bend Radius	Vacuum in HG.	Weight Per Ft.
260-2315	REB150	1.5"	2.03"	250 psi	3.0"	29"	0.93-lbs
260-2320	REB200	2"	2.537"	250 psi	4.0"	29"	1.21-lbs
260-2325	REB250	2.5"	3.08"	200 psi	5.5"	29"	1.67-lbs
260-2330	REB300	3"	3.601"	200 psi	6.0"	29"	2.03-lbs

REB-G ExtremeFlex™ Beverage Hose



Tube:	White Chlorobutyl
Cover:	Gray Corrugated Chemivic w/ Blue Stripe
Reinforcement:	Spiral-plied fabrics w/ double steel wire helix
Color:	Gray
Temp. Range:	-30° to 220°F
Max. Length:	100'
Approvals:	3-A, FDA, USDA

Lightweight and flexible hose, suitable for beverage and other edible liquid transfer applications in a processing plant. The microbe-resistant tube works to not impart taste or smell onto your products.

Stock #	Model	ID	OD	Working Pressure	Min. Bend Radius	Vacuum in HG.	Weight Per Ft.
260-2115	REB-G150	1.5"	2.02"	250 psi	2.3"	29"	0.92-lbs
260-2120	REB-G200	2"	2.53"	250 psi	3.0"	29"	1.20-lbs
260-2125	REB-G250	2.5"	3.07"	250 psi	4.0"	29"	1.65-lbs
260-2130	REB-G300	3"	3.59"	200 psi	4.5"	29"	2.02-lbs

*3-A 62-02 standard applies only to assemblies of ¾" diameter and larger.

WARNING: Working pressure ratings are based on ambient temperature. Working pressure and vacuum ratings will decrease as temperatures increase.

Rubber Hose

RES Flex-Rite™ Suction & Discharge Hose



- Tube:** White EPDM
- Cover:** Light Blue, EPDM Synthetic Rubber
- Reinforcement:** Two polyester spirals w/ dual helix wire
- Color:** Blue
- Temp. Range:** -40° to 275°F
- Max. Length:** 130'
- Approvals:** 3-A*, FDA, USDA

Durable and flexible hose that is able to withstand high temperature applications to help deliver your products safely and effectively. The smooth inner lining will not impart taste or odor onto your products. Consider this suction and discharge hose for use with milk, dairy, food and beverage, as well as cosmetics, pharmaceutical, and CIP applications.

Stock #	Model	ID	OD	Working Pressure	Min. Bend Radius	Vacuum in HG.	Weight Per Ft.
113-6205	RES050	0.5"	0.94"	150 psi	2.0"	29"	0.28-lbs
113-6207	RES075	0.75"	1.22"	150 psi	2.5"	29"	0.47-lbs
113-6210	RES100	1"	1.46"	150 psi	3.5"	29"	0.57-lbs
113-6215	RES150	1.5"	2.00"	150 psi	6.0"	29"	0.88-lbs
113-6220	RES200	2"	2.52"	150 psi	7.5"	29"	1.13-lbs
113-6225	RES250	2.5"	3.17"	150 psi	9.0"	29"	1.87-lbs
113-6230	RES300	3"	3.70"	150 psi	11.0"	29"	2.24-lbs

RCR Flex-Rite™ Crush Resistant Hose



- Tube:** White Chlorobutyl
- Cover:** Orange EPDM w/ White Stripe
- Reinforcement:** Spiral-plied synthetic fabric w/ monofilament helix
- Color:** Orange
- Temp. Range:** -30° to 225°F
- Max. Length:** 100'
- Approvals:** 3-A, FDA, USDA

Ideal for use in receiving bays and high traffic areas, this premium crush resistant hose's color gives it high-visibility while the reinforcement is designed to spring back to its original shape after being twisted, kinked or run over. The bacteria resistant construction will not impart taste or odor onto your products. With almost a full vacuum rating, this hose is suitable for many applications including wine, beer, and other sanitary liquid food processes.

Stock #	Model	ID	OD	Working Pressure	Min. Bend Radius	Vacuum in HG.	Weight Per Ft.
116-2715	RCR150	1.5"	2.11"	250 psi	4.0"	27"	0.98-lbs
116-2720	RCR200	2"	2.68"	250 psi	7.0"	27"	1.38-lbs
116-2725	RCR250	2.5"	3.21"	250 psi	10.0"	27"	1.78-lbs
113-2633	RCR300	3"	3.85"	250 psi	12.0"	27"	2.45-lbs

GCR Saint Gobain Crush Resistant Hose



- Tube:** Santoprene Rubber
- Cover:** Red EPDM w/ White Stripe
- Reinforcement:** Multiple fabric spirals w/ monofilament helix
- Color:** Red
- Temp. Range:** -40° to 225°F
- Max. Length:** 100'
- Approvals:** 3-A, FDA, USDA

Transports a wide variety of dairy and food products—suited especially for receiving bay or raw product intake applications, as the seamless tube will not impart taste or odor. Slightly heavier and less flexible than our suction and discharge hose, the crush resistant hose has a high working pressure to deliver your products safely and effectively. *Caution: GCR is rated at 20" Hg (about 75% vacuum) but will actually pull a full vacuum when new. However, repeated collapsing of the hose will create a "soft spot" that reduces vacuum capabilities, even though it rebounds to its original shape.*

Stock #	Model	ID	OD	Working Pressure	Min. Bend Radius	Vacuum in HG.	Weight Per Ft.
671-2615	GCR150	1.5"	2.16"	250 psi	5.0"	20"	1.05-lbs
671-2620	GCR200	2"	2.66"	250 psi	7.0"	20"	1.33-lbs
671-2625	GCR250	2.5"	3.19"	250 psi	12.0"	20"	1.77-lbs
671-2630	GCR300	3"	3.75"	250 psi	18.0"	20"	2.30-lbs
671-2640	GCR400	4"	4.75"	200 psi	36.0"	20"	2.94-lbs

*3-A 62-02 standard applies only to assemblies of 3/4" diameter and larger.

WARNING: Working pressure ratings are based on ambient temperature. Working pressure and vacuum ratings will decrease as temperatures increase.

Rubber Hose

SSW Saint Gobain Discharge Hose



Tube:	White Chlorobutyl
Cover:	Blue EPDM
Reinforcement:	Two fabric spirals
Color:	Blue
Temp. Range:	-40° to 225°F
Max. Length:	100'
Approvals:	3-A, FDA, USDA, CFIA

Lightweight and easy to maneuver hose, suitable for straight discharge applications. Ideal for overhead CIP wash units, as the super smooth seamless tube will not impart taste or odor and handles most CIP solutions with ease. Cover maintains a clean appearance and resists abrasion. Softwall hose not designed for suction uses.

Stock #	Model	ID	OD	Working Pressure	Min. Bend Radius	Vacuum in HG.	Weight Per Ft.
671-2415	SSW150	1.5"	2.16"	250 psi	-	-	1-lb
671-2420	SSW200	2"	2.66"	250 psi	-	-	1.25-lbs
671-2425	SSW250	2.5"	3.19"	250 psi	-	-	1.66-lbs
671-2430	SSW300	3"	3.75"	250 psi	-	-	2.23-lbs

RCT Flex-Rite™ Transfer Hose



Tube:	White Nitrile
Cover:	White Nitrile w/ White Stripe
Reinforcement:	Spiral-plied synthetic fabric w/ dual wire helix
Color:	White
Temp. Range:	-25° to 250°F
Max. Length:	100'
Approvals:	3-A, FDA, USDA

An excellent choice for edible oils and personal care products as well as most dairy applications. Designed to handle high temperature applications while maintaining your product's original color, taste, and odor. A dual wire helix makes this hose extremely flexible and easy to handle.

Stock #	Model	ID	OD	Working Pressure	Min. Bend Radius	Vacuum in HG.	Weight Per Ft.
113-1110	RCT100	1"	1.50"	150 psi	3.5"	29"	0.95-lbs
113-1115	RCT150	1.5"	2.13"	150 psi	4.0"	29"	1.10-lbs
113-1120	RCT200	2"	2.64"	150 psi	4.5"	29"	1.45-lbs
113-1125	RCT250	2.5"	3.19"	150 psi	6.0"	29"	1.90-lbs
113-1130	RCT300	3"	3.76"	150 psi	7.0"	29"	2.68-lbs
113-1140	RCT400	4"	4.77"	150 psi	10.5"	29"	3.54-lbs

FGR Saint Gobain Suction & Discharge Hose



Tube:	White Nitrile-PVC Blend
Cover:	Gray EPDM w/ Red Stripe
Reinforcement:	Galvanized carbon steel helix wire
Color:	Gray
Temp. Range:	-40° to 250°F
Max. Length:	100'
Approvals:	3-A, FDA, USDA

Ideal for many demanding applications throughout the food and beverage industry. The multi-fabric reinforced outer shell is resistant to chemicals and the single-helix carbon steel wire frame provides optimal protection from multiple bends and high pressure situations.

Stock #	Model	ID	OD	Working Pressure	Min. Bend Radius	Vacuum in HG.	Weight Per Ft.
671-2512	HOSFGR-16	1"	1.52"	350 psi	3.0"	29.9"	0.69-lbs
671-2517	HOSFGR-24	1.5"	2.02"	300 psi	4.0"	29.9"	0.98-lbs
671-2527	HOSFGR-32	2"	2.52"	250 psi	4.5"	29.9"	1.26-lbs
671-2526	HOSFGR-40	2.5"	3.14"	150 psi	6.0"	29.9"	1.97-lbs
671-2534	HOSFGR-48	3"	3.65"	150 psi	7.0"	29.9"	2.37-lbs

*3-A 62-02 standard applies only to assemblies of 3/4" diameter and larger.

WARNING: Working pressure ratings are based on ambient temperature. Working pressure and vacuum ratings will decrease as temperatures increase.

Rubber Hose

RBT Flex-Rite™ Beverage Transfer Hose



- Tube:** White EPDM
- Cover:** Purple EPDM w/ White Stripe
- Reinforcement:** Spiral-plyed synthetic fabric, 4 plies 1.5" - 6 plies 2" and over
- Color:** Purple
- Temp. Range:** -40° to 225°F
- Max. Length:** 100'
- Approvals:** 3-A, FDA, USDA

Heavy-duty, high pressure hose with limited suction capability. Ideally suited for transferring liquid products in breweries and wineries, as the bounce back design resists damage from kinking or flattening in high traffic areas.

Stock #	Model	ID	OD	Working Pressure	Min. Bend Radius	Vacuum in HG.	Weight Per Ft.
116-2110	RBT100	1"	1.66"	250 psi	4.0"	20"	0.74-lbs
116-2115	RBT150	1.5"	2.20"	250 psi	5.5"	20"	1.10-lbs
116-2120	RBT200	2"	2.89"	250 psi	6.5"	20"	1.84-lbs
116-2130	RBT300	3"	4.09"	250 psi	10.0"	20"	3.57-lbs

RWS Flex-Rite™ Wine & Spirits Hose



- Tube:** White Chlorobutyl
- Cover:** Red Thermoplastic w/ White Stripe
- Reinforcement:** High strength synthetic cord w/ steel wire helix
- Color:** Red
- Temp. Range:** -25° to 250°F
- Max. Length:** 130'
- Approvals:** 3-A, FDA, USDA

Designed to give you extra flexibility and wear resistance. The lightweight frame and reinforced inner cover helps ensure low friction and better movement of your products is achieved while imparting no color, taste, and odor.

Stock #	Model	ID	OD	Working Pressure	Min. Bend Radius	Vacuum in HG.	Weight Per Ft.
116-2215	RWS150	1.5"	2.09"	150 psi	4.0"	29"	1.00-lbs
116-2220	RWS200	2"	2.69"	150 psi	5.0"	29"	1.39-lbs
116-2225	RWS250	2.5"	3.13"	150 psi	6.5"	29"	1.68-lbs
116-2230	RWS300	3"	3.64"	150 psi	7.5"	29"	2.11-lbs
116-2240	RWS400	4"	4.77"	150 psi	9.0"	29"	3.15-lbs

RWS-L Flex-Rite™ Wine & Spirits Lite Hose



- Tube:** White Chlorobutyl
- Cover:** Gray Thermoplastic w/ White Stripe
- Reinforcement:** High strength synthetic cord w/ steel wire helix
- Color:** Gray
- Temp. Range:** -40° to 250°F
- Max. Length:** 130'
- Approvals:** 3-A, FDA, USDA

Lightweight, low force to bend hose with a polymer blended exterior that is abrasion resistant. This suction and discharge hose is designed to be flexible and resist friction to ensure ease of movement. The smooth inner tube delivers a taste and odor free flow.

Stock #	Model	ID	OD	Working Pressure	Min. Bend Radius	Vacuum in HG.	Weight Per Ft.
116-2415	RWS-L150	1.5"	1.93"	115 psi	3.0"	27"	0.65-lbs
116-2420	RWS-L200	2"	2.44"	115 psi	4.0"	27"	0.85-lbs
116-2425	RWS-L250	2.5"	2.97"	115 psi	5.0"	27"	1.15-lbs
116-2430	RWS-L300	3"	3.46"	115 psi	6.0"	27"	1.37-lbs

*3-A 62-02 standard applies only to assemblies of 3/4" diameter and larger.

WARNING: Working pressure ratings are based on ambient temperature. Working pressure and vacuum ratings will decrease as temperatures increase.

Fluoropolymer Lined Hose

TLCT Saint Gobain TLCT/WTLCT/SFTL Hose



- Tube:** FEP
Cover: Green EPDM Rubber w/ White Stripe
Reinforcement: Multiple polyester pycord and EPDM rubber, double helix, high tensile strength carbon steel wire
Color: Green
Temp. Range: -40° to 350°F
Max. Length: 8TLCT to 32TLCT: 100'
 40TLCT to 48TLCT: 60'
 64TLCT: 30'
Approvals: 3-A, FDA, USP Class VI Standards

Suited for demanding applications where flexibility and durability are needed. The chemical resistant outer shell, smooth inner shell and reinforced design helps transport your products safely and efficiently.

Stock #	Model	ID	OD	Working Pressure	Min. Bend Radius	Vacuum in HG.	Weight Per Ft.
671-3105	8TLCT	0.5"	1.00"	500 psi	3.0"	29.9"	0.42-lbs
671-3107	12TLCT	0.75"	1.30"	500 psi	4.5"	29.9"	0.59-lbs
671-3110	16TLCT	1"	1.56"	450 psi	6.0"	29.9"	0.75-lbs
671-3112	20TLCT	1.25"	1.78"	320 psi	9.0"	29.9"	0.91-lbs
671-3115	24TLCT	1.5"	2.13"	300 psi	11.0"	29.9"	1.21-lbs
671-3120	32TLCT	2"	2.68"	250 psi	13.5"	29.9"	1.70-lbs
671-3125	40TLCT	2.5"	3.16"	200 psi	20.0"	29.9"	2.00-lbs
671-3130	48TLCT	3"	3.69"	150 psi	22.0"	29.9"	2.52-lbs
671-3140	64TLCT	4"	4.69"	150 psi	40.0"	29.9"	3.79-lbs

TRP Flex-Rite™ Suction & Discharge Hose



- Tube:** PTFE
Cover: Green EPDM, Smooth
Reinforcement: Stainless Steel Wire Helices
Color: Green
Temp. Range: -40° to 302°F
Max. Length: TRP050 to TRP200: 130'
 TRP250 to TRP400: 65'
Approvals: 3-A*, FDA, USDA, USP Class VI Standards

Designed for use in the food, cosmetic, chemical and pharmaceutical industries. The high-quality frame and smooth inner coating provide safe transportation of your products without imparting taste or odor.

Stock #	Model	ID	OD	Working Pressure	Min. Bend Radius	Vacuum in HG.	Weight Per Ft.
113-1205	TRP050	0.5"	1.00"	250 PSI	3.0"	28"	0.34-lbs
113-1207	TRP075	0.75"	1.22"	250 PSI	4.3"	28"	0.44-lbs
113-1210	TRP100	1"	1.46"	250 PSI	5.9"	28"	0.54-lbs
113-1215	TRP150	1.5"	2.00"	250 PSI	9.5"	28"	0.9-lbs
113-1220	TRP200	2"	2.60"	250 PSI	12.6"	28"	1.38-lbs
113-1225	TRP250	2.5"	3.13"	250 PSI	16.9"	28"	1.74-lbs
113-1230	TRP300	3"	3.58"	250 PSI	20.1"	28"	2.30-lbs
113-1240	TRP400	4"	4.57"	250 PSI	25.6"	28"	2.82-lbs

**Need help selecting the right hose for your application?
 Contact our hose specialists for assistance.**

*3-A 62-02 standard applies only to assemblies of 3/4" diameter and larger.

WARNING: Working pressure ratings are based on ambient temperature. Working pressure and vacuum ratings will decrease as temperatures increase.

Stainless Steel Braided Hose

TSC Silicone Covered Smooth Bore Hose



Tube:	PTFE Unpigmented, (anti-static options available)
Cover:	White, Platinum Cured Silicone
Reinforcement:	Stainless Steel Braid
Color:	White
Temp. Range:	-100° to 400°F
Max. Length:	50'
Approvals:	3-A*, FDA, USP Class VI Standards

Durable and flexible hose, suitable for handling pharmaceutical, biotech and food industry applications. This hose will not impart taste or odor to products being transferred and provides cleaning ease both inside and out.

Model	ID	OD	Working Pressure	Min. Bend Radius	Vacuum in HG.	Weight Per Ft.
TSC025	0.25"	0.46"	1100 psi	0.7"	29"	0.12-lbs
TSC037	0.375"	0.61"	1000 psi	1.0"	29"	0.14-lbs
TSC050	0.5"	0.84"	870 psi	1.5"	29"	0.25-lbs
TSC075	0.75"	1.12"	650 psi	2.5"	29"	0.42-lbs
TSC100	1"	1.45"	580 psi	4.0"	29"	0.57-lbs
TSC150	1.5"	2.03"	430 psi	6.7"	29"	1.14-lbs
TSC200	2"	2.56"	400 psi	8.2"	29"	1.58-lbs
TSC250	2.5"	3.17"	290 psi	11.8"	29"	2.41-lbs
TSC300	3"	3.65"	220 psi	13.8"	29"	2.96-lbs

TSB Stainless Steel Braided Smooth Bore Hose



Tube:	PTFE Unpigmented
Cover:	Stainless Steel Braid
Reinforcement:	Double Braided (TSB100 only)
Color:	Stainless Steel
Temp. Range:	-20° to 425°F
Max. Length:	50'
Approvals:	3-A*, FDA, USP Class VI Standards

Excellent for fixed applications where minimal abuse, handling or flexing exist. Available for "Flaired Through" applications. HOSE COVER OPTIONS AVAILABLE.

Model	ID	OD	Working Pressure	Min. Bend Radius	Vacuum in HG.	Weight Per Ft.
TSB025	0.25"	0.41"	3000 psi	1.7"	30"	0.16-lbs
TSB037	0.375"	0.53"	2500 psi	2.0"	30"	0.16-lbs
TSB050	0.5"	0.63"	1425 psi	6.5"	30"	0.16-lbs
TSB075	0.75"	0.86"	1000 psi	8.2"	30"	0.20-lbs
TSB100	1"	1.19"	1000 psi	12.0"	30"	0.53-lbs

TCB Stainless Steel Braided Convoluted



Tube:	PTFE Unpigmented
Cover:	316 Stainless Steel Braid
Reinforcement:	N/A
Color:	Stainless Steel
Temp. Range:	-20° to 425°F
Max. Length:	50'
Approvals:	3-A*, FDA, USP Class VI Standards

Crush resistant hose that is easy to flex and has a tighter bend radius compared to smooth bore. Open pitched, seamless, helical convolutions provide for easy cleaning and transport of pharmaceuticals, chemicals, food and beverages. HOSE COVER OPTIONS AVAILABLE.

Model	ID	OD	Working Pressure	Min. Bend Radius	Vacuum in HG.	Weight Per Ft.
TCB050	0.5"	0.75"	1425 psi	2.0"	29"	0.19-lbs
TCB075	0.75"	1.05"	1300 psi	2.7"	29"	0.29-lbs
TCB100	1"	1.35"	1100 psi	4.0"	29"	0.51-lbs
TCB150	1.5"	2.03"	700 psi	6.0"	29"	0.81-lbs
TCB200	2"	2.46"	525 psi	7.5"	29"	1.00-lbs

*3-A 62-02 standard applies only to assemblies of 3/4" diameter and larger.

WARNING: Working pressure ratings are based on ambient temperature. Working pressure and vacuum ratings will decrease as temperatures increase.

Silicone Hose

SXW Flex-Rite™ Wire Reinforced Discharge Hose



- Tube:** Platinum Cured Silicone
- Cover:** White Translucent (colors available)
- Reinforcement:** Four ply, polyester fabric w/ 316L stainless steel wire helix
- Color:** White Translucent
- Temp. Range:** -100° to 395°F
- Max. Length:** 130'
- Approvals:** 3-A*, FDA, USDA, USP Class VI Standards

The low force to bend characteristics this hose achieves are suitable for pharmaceutical, cosmetic and food industry applications. The reinforced frame strikes the perfect balance between flexibility and durability.

Stock #	Model	ID	OD	Working Pressure	Min. Bend Radius	Weight Per Ft.	Vacuum in HG.
113-2752	SXW050	0.5"	0.94"	150 psi	1.5"	0.31-lbs	28"
113-2775	SXW075	0.75"	1.18"	150 psi	2.0"	0.40-lbs	28"
113-2713	SXW100	1"	1.42"	150 psi	2.5"	0.49-lbs	28"
113-2717	SXW150	1.5"	2.00"	125 psi	4.5"	0.81-lbs	28"
113-2722	SXW200	2"	2.52"	110 psi	5.5"	1.05-lbs	28"
113-2726	SXW250	2.5"	3.09"	85 psi	7.0"	1.55-lbs	28"
113-2731	SXW300	3"	3.58"	70 psi	9.0"	1.82-lbs	28"
113-2741	SXW400	4"	4.61"	50 psi	14.5"	2.38-lbs	28"

SXD Flex-Rite™ Fabric Reinforced Discharge Hose



- Tube:** Platinum Cured Silicone
- Cover:** White Translucent (colors available)
- Reinforcement:** Four ply, polyester fabric
- Color:** White Translucent
- Temp. Range:** -100° to 395°F
- Max. Length:** 130'
- Approvals:** 3-A*, FDA, USDA, USP Class VI Standards

Designed for bulk transfer, high-pressure and vacuum process applications due in part to the low force to bend capabilities.

Stock #	Model	ID	OD	Working Pressure	Min. Bend Radius	Weight Per Ft.	Vacuum in HG.
113-2751	SXD050	0.5"	1.00"	150 psi	8.0"	0.27-lbs	26"
113-2756	SXD075	0.75"	1.22"	150 psi	10.0"	0.37-lbs	22"
113-2710	SXD100	1"	1.46"	125 psi	12.0"	0.46-lbs	18"
113-2716	SXD150	1.5"	1.97"	85 psi	-	0.64-lbs	12"
113-2721	SXD200	2"	2.48"	70 psi	-	0.83-lbs	8"
113-2727	SXD250	2.5"	3.01"	60 psi	-	1.13-lbs	6"
113-2732	SXD300	3"	3.50"	45 psi	-	1.33-lbs	4"

SSD Single Braid Discharge Hose



- Tube:** Platinum Cured Silicone
- Cover:** White Translucent
- Reinforcement:** Single ply, polyester braid
- Color:** White Translucent
- Temp. Range:** -100° to 395°F
- Max. Length:** 50'
- Approvals:** 3-A*, FDA, USDA, USP Class VI Standards

Designed to handle mid-range pressure applications due to the reinforced lining and flexible frame. Tough outer lining is able to resist weathering and extreme temperatures.

Stock #	Model	ID	OD	Working Pressure	Min. Bend Radius	Weight Per Ft.	Vacuum in HG.
113-2701	SSD025	0.25"	0.52"	140 psi	1.3"	0.09-lbs	-
113-2702	SSD037	0.375"	0.66"	135 psi	2.0"	0.13-lbs	-
113-2709	SSD050	0.5"	0.80"	100 psi	2.5"	0.18-lbs	-
113-2758	SSD075	0.75"	1.10"	90 psi	3.5"	0.26-lbs	-
113-2712	SSD100	1"	1.36"	60 psi	5.0"	0.31-lbs	-

*3-A 62-02 standard applies only to assemblies of 3/4" diameter and larger.

WARNING: Working pressure ratings are based on ambient temperature. Working pressure and vacuum ratings will decrease as temperatures increase.

Silicone Hose

SPD Saint Gobain Single Ply Discharge Hose



Tube: Platinum Cured Silicone
Cover: White Translucent
Reinforcement: Single ply polyester braid
Color: White Translucent
Temp. Range: -80° to 350°F
Max Length: SPD037 to SPD075: 100'
 SPD025, SPD100, and SPD150: 50'
Approvals: 3-A*, FDA, USP Class IV Silicone

Capable of transporting a variety of food and beverage applications as well as CIP and SIP cleaning where no vacuum rating is required. Sterilizable and autoclavable.

Stock #	Model	ID	OD	Working Pressure	Min. Bend Radius	Vacuum in HG.	Weight Per Ft.
671-2702	SPD025	0.25"	0.50"	155 psi	1.5"	-	0.10-lbs
671-2703	SPD037	0.375"	0.66"	125 psi	2.0"	-	0.14-lbs
671-2705	SPD050	0.5"	0.84"	105 psi	2.5"	-	0.19-lbs
671-2706	SPD062	0.625"	0.94"	90 psi	3.0"	-	0.25-lbs
671-2707	SPD075	0.75"	1.13"	65 psi	3.5"	-	0.30-lbs
671-2710	SPD100	1"	1.38"	55 psi	5.0"	-	0.40-lbs
671-2711	SPD150	1.5"	1.84"	45 psi	6.0"	-	0.58-lbs

FPD Saint Gobain Four Ply Discharge Hose



Tube: Platinum Cured Silicone
Cover: White Translucent
Reinforcement: Four ply polyester braid
Color: White Translucent
Temp. Range: -80° to 350°F
Max Length: 12'
Approvals: 3-A*, FDA, USP Class IV Silicone

Specifically designed for CIP and SIP cleaning thanks to the tough inner lining that is able to handle high pressure and won't impart taste or odor onto your products. Sterilizable and autoclavable.

Stock #	Model	ID	OD	Working Pressure	Min. Bend Radius	Vacuum in HG.	Weight Per Ft.
671-2712	FPD050	0.5"	0.91"	140 psi	8.0"	-	0.23-lbs
671-2713	FPD075	0.75"	1.16"	125 psi	10.0"	-	0.30-lbs
671-2714	FPD100	1"	1.41"	110 psi	12.0"	-	0.38-lbs
671-2715	FPD150	1.5"	1.91"	100 psi	-	-	0.52-lbs
671-2720	FPD200	2"	2.41"	100 psi	-	-	0.73-lbs
671-2730	FPD300	3"	3.41"	50 psi	-	-	0.95-lbs

FPW Saint Gobain Wire Reinforced Hose



Tube: Platinum Cured Silicone
Cover: White Translucent
Reinforcement: Four ply, polyester fabric w/ 316L stainless steel wire helix
Color: White Translucent
Temp. Range: -80° to 350°F
Max Length: 12'
Approvals: 3-A*, FDA, USP Class IV Silicone

Designed to be used in situations that require a silicone hose that can resist high temperatures and pressures. Won't impart taste or odor, and is suitable for CIP and SIP cleaning. Sterilizable and autoclavable.

Stock #	Model	ID	OD	Working Pressure	Min. Bend Radius	Vacuum in HG.	Weight Per Ft.
671-2750	FPW050	0.5"	0.91"	200 psi	2.5"	29"	0.28-lbs
671-2755	FPW075	0.75"	1.16"	200 psi	3.5"	29"	0.30-lbs
671-2760	FPW100	1"	1.41"	200 psi	5.0"	29"	0.44-lbs
671-2765	FPW150	1.5"	1.91"	200 psi	8.0"	29"	0.58-lbs
671-2770	FPW200	2"	2.41"	175 psi	11.0"	29"	0.88-lbs
671-2775	FPW250	2.5"	2.91"	175 psi	13.0"	29"	1.10-lbs
671-2780	FPW300	3"	3.41"	150 psi	17.0"	29"	1.57-lbs

*3-A 62-02 standard applies only to assemblies of 3/4" diameter and larger.

WARNING: Working pressure ratings are based on ambient temperature. Working pressure and vacuum ratings will decrease as temperatures increase.

PVC Tubing

CSS Saint Gobain Wire Reinforced Tubing



Tube: PVC
Reinforcement: Clear Extrusion w/ Steel Wire Helix
Color: Clear
Temp. Range: 25° to 150°F
Max. Length: CSS050: 100'
 CSS150 to CSS300: 50'
Approvals: 3-A*, FDA, USDA, USP Class VI Standards

Heavy-duty clear PVC tubing features a steel wire reinforcement which helps prevent kinking and collapsing. This tubing is suitable for milk handling and food processing applications.

Stock #	Model	ID	OD	Working Pressure	Min. Bend Radius	Vacuum in HG.	Weight Per Ft.
671-2105	CSS050	0.5"	0.81"	150 psi	2.0"	29"	0.21-lbs
671-2107	CSS075	0.75"	1.13"	150 psi	3.0"	29"	0.36-lbs
671-2110	CSS100	1"	1.38"	100 psi	4.0"	29"	0.44-lbs
671-2115	CSS150	1.5"	1.91"	50 psi	6.0"	29"	0.58-lbs
671-2120	CSS200	2"	2.50"	50 psi	8.0"	29"	0.84-lbs
671-2125	CSS250	2.5"	3.00"	50 psi	10.0"	29"	1.38-lbs
671-2130	CSS300	3"	3.50"	50 psi	12.0"	29"	1.62-lbs

CBT Saint Gobain Braid Reinforced Tubing



Tube: PVC
Reinforcement: Extrusion w/ Polyester Textile Inner Braid
Color: Clear
Temp. Range: 25° to 150°F
Max. Length: CBT050 to CBT100: 100'
 CBT150 and CBT200: 50'
Approvals: 3-A*, FDA, USDA, USP Class VI Standards

Flexible, crystal clear tubing reinforced with multiple polyester braids is suitable for a wide variety of food and beverage applications.

Stock #	Model	ID	OD	Working Pressure	Min. Bend Radius	Vacuum in HG.	Weight Per Ft.
671-2805	CBT050	0.5"	0.81"	250 psi	4.0"	-	0.17-lbs
671-2807	CBT075	0.75"	1.13"	200 psi	5.0"	-	0.30-lbs
671-2810	CBT100	1"	1.38"	150 psi	6.0"	-	0.38-lbs
671-2815	CBT150	1.5"	1.91"	100 psi	8.0"	-	0.64-lbs
671-2820	CBT200	2"	2.50"	75 psi	12.0"	-	0.94-lbs

CCT Saint Gobain Clear Tubing



Tube: PVC
Reinforcement: Clear Extrusion—No Reinforcement
Color: Clear
Temp. Range: 25° to 150°F
Max. Length: CCT050 to CCT100: 100'
 CCT150 and CCT200: 50'
Approvals: 3-A*, FDA, USDA, USP Class VI Standards

Clear PVC food and beverage tubing. Works well for air lines and weak chemical and acid transfer. Applications for smaller sizes include bottling plants, beverage dispensing and laboratory tubing.

Stock #	Model	ID	OD	Working Pressure	Min. Bend Radius	Vacuum in HG.	Weight Per Ft.
671-2850	CCT050	0.5"	0.81"	45 psi	4.5"	-	0.13-lbs
671-2875	CCT075	0.75"	1.13"	40 psi	5.5"	-	0.30-lbs
671-2880	CCT100	1"	1.38"	35 psi	9.0"	-	0.38-lbs
671-2885	CCT150	1.5"	1.91"	35 psi	15.0"	-	0.54-lbs
671-2890	CCT200	2"	2.50"	35 psi	18.0"	-	0.96-lbs

*3-A 62-02 standard applies only to assemblies of 3/4" diameter and larger.

WARNING: Working pressure ratings are based on ambient temperature. Working pressure and vacuum ratings will decrease as temperatures increase.

How to Order Sanitary Hose Assemblies

Build Your Assembly Part Number

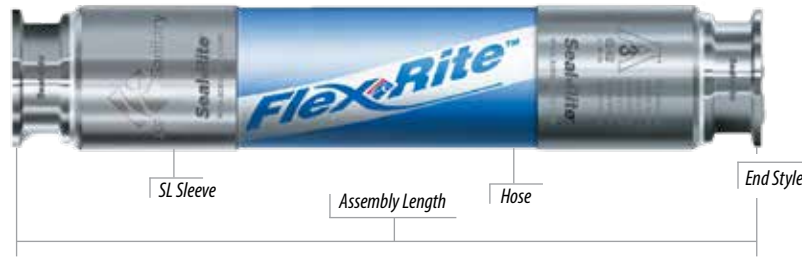

PSD	200	SL	200 TC	200 TC	S	180 (inches)
Hose	ID Size	Fitting Style	Size First End Connection	Size Second End Connection	Hose Sleeve Stainless	Assembly Length

Rubber

PSD	Gray Suction & Discharge
PSDW	White Suction & Discharge
GRC	Red Crush Resistant
SSW	Blue Softwall Discharge
REB	Red ExtremeFlex Bev
REBG	Gray ExtremeFlex Bev
RSD	Gray Suction & Discharge
RSDR	Red Suction & Discharge
RSDB	Blue Suction & Discharge
RES	LT Blue Premium S & D
RCR	Orange Crush Resistant
RBT	Purple Beverage
RWS	Red Wine & Sprits
RCT	White Comestible
TLCT	Green FEP Lined
TRP	Green EPDM/FEP Lined

PVC

CCT	Clear Tubing
CBT	Braided Tubing
CSS	Wire Helix

Silicone

SXW	Silicone Wire Reinforced
SXD	Silicone Multi Ply Discharge
SDB	Silicone Double Braid Discharge
SSD	Silicone Single Braid Discharge

Stainless Steel Overbraid PTFE

TSC	Silicone Covered PTFE Smooth Bore
TSB	SS Braided PTFE Smooth Bore
TCB	SS Braided PTFE Convuluted

Size Code

025	= 1/4"
037	= 3/8"
050	= 1/2"
062	= 5/8"
075	= 3/4"
100	= 1"
150	= 1-1/2"
200	= 2"
250	= 2-1/2"
300	= 3"
400	= 4"
600	= 6"

Coupler Style

Radial Crimp

End Connection

- TC = Sanitary Clamp
- BS = Bevel Seat with Hex Nut
- BT = Bevel Male Thread
- IF = Female I-Line
- IM = Male I-Line
- JP = John Perry with Hex Nut
- JT = John Perry Male Thread
- MT = Male Pipe Thread
- TE = Tube End (Butt Weld)
- DF = Cam & Groove Female
- AM = Cam & Groove Male
- AF = Flange
- QL = Q-Line

Overall length tolerances for assemblies are:

- 1/4" on assemblies to 24"
- 1/2" on assemblies 25" to 60"
- 1% on assemblies over 60"

Build Your Custom Assembly in Just 7 Easy Steps:

- 1** Select code for hose style
- 2** Specify hose ID
- 3** Coupler style
SL = radial crimp/permanent
- 4 & 5** Specify size and connection of each end fitting
- 6** Hose sleeve material
S = Stainless Steel
- 7** Specify overall assembly length in inches

Need help?

We can recommend the right hose for your application!
Call our hose specialists for assistance.

*3-A 62-02 standard applies only to assemblies of 3/4" diameter and larger.

WARNING: Working pressure ratings are based on ambient temperature. Working pressure and vacuum ratings will decrease as temperatures increase.

ReSeal® Reusable Fittings

ReSeal® fittings are 3-A and meet the stringent requirements of critical processing industries while being totally reusable. Whether your sanitary hose assembly needs frequent inspection, becomes kinked, is damaged in some way, or simply wears out, our ReSeal stainless steel fittings can be dismantled and reattached to a new length of hose. You'll still have to buy the new hose, but being able to reuse the ReSeal fittings can save you between 50% and 80% of the cost of a completely new assembly.

The full flow smooth bore and compression seal design of ReSeal fittings means there are no obstructions on the inner surface of the fitting—and obstructions provide the perfect breeding ground for harmful bacteria and other contaminants. The faster you can clean a sanitary fitting assembly, the sooner you can restart your operation. ReSeal fittings are designed for CIP convenience—no disassembly required. Depending on the hose applications, they are also suitable for COP, SIP, and are totally autoclavable.

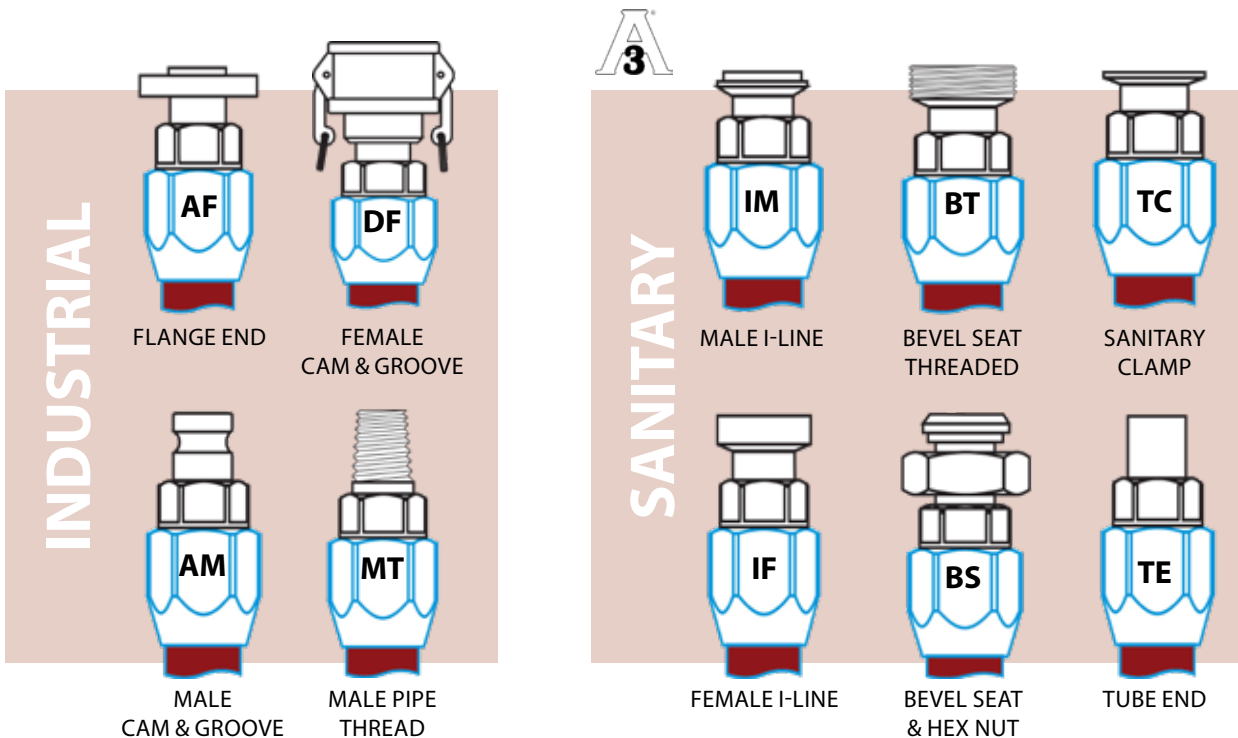
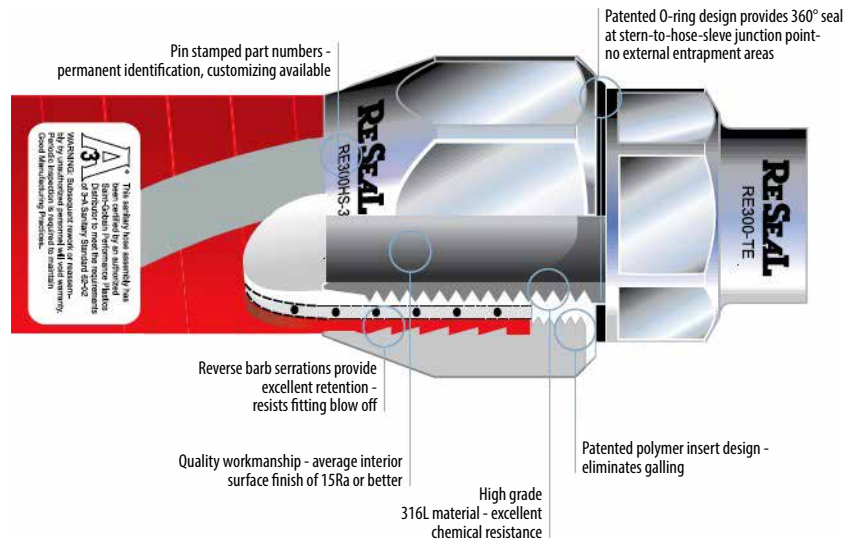

*3-A 62-02 standard applies only to assemblies of 3/4" diameter and larger.

WARNING: Working pressure ratings are based on ambient temperature. Working pressure and vacuum ratings will decrease as temperatures increase.

Rubber Hose

PSD *Saint Gobain Suction & Discharge Hose*



Tube: White Chlorobutyl
Cover: Light Gray or White EPDM
Reinforcement: Two fabric spirals w/ helix wire
Color: PSD - Gray, all sizes
 PSDW - White, 1.5", 2", 3" only
Temp. Range: -40° to 225°F
Max. Length: 100'
Approvals: 3-A*, FDA, USDA

High-quality and versatile hose that is ideal for transporting many food plant applications. The smooth inner lining works to not impart taste or odor to your product and is highly resistant to common CIP solutions, plus the abrasion resistant cover helps maintain a clean appearance.

Stock #	Model	ID	OD	Working Pressure	Min. Bend Radius	Vacuum in HG.	Weight Per Ft.
671-2505	PSD050	0.5"	1.03"	150 psi	2.0"	29"	0.40-lbs
671-2507	PSD075	0.75"	1.25"	150 psi	3.0"	29"	0.56-lbs
671-2510	PSD100	1"	1.53"	150 psi	4.0"	29"	0.65-lbs
671-2515	PSD150	1.5"	2.16"	150 psi	6.0"	29"	1.07-lbs
671-2520	PSD200	2"	2.66"	150 psi	7.0"	29"	1.43-lbs
671-2525	PSD250	2.5"	3.19"	150 psi	8.0"	29"	2.08-lbs
671-2530	PSD300	3"	3.75"	150 psi	9.0"	29"	2.63-lbs
671-2540	PSD400	4"	4.75"	150 psi	12.0"	29"	3.14-lbs
671-2518	PSDW150	1.5"	2.16"	150 psi	6.0"	29"	1.07-lbs
671-2523	PSDW200	2"	2.66"	150 psi	7.0"	29"	1.53-lbs
671-2533	PSDW300	3"	3.75"	150 psi	9.0"	29"	2.63-lbs

XFR *Saint Gobain Suction & Discharge Hose*



Tube: White Bromobutyl
Cover: Blue Thermoplastic w/ White Stripe
Reinforcement: 316L stainless steel wire helix, synthetic plies
Color: Blue
Temp. Range: -40° to 248°F
Max. Length: 130'
Approvals: 3-A, FDA

Durable, lightweight, and extra flexible hose, suitable for various food processing applications. The inner tube reduces the risk of flavor contamination and is compatible with many types of food products such as beer, wine, and milk. With a lower weight per foot than traditional suction and discharge hoses, this hose is easy to bend and attach to most pumps and tanks.

Stock #	Model	ID	OD	Working Pressure	Min. Bend Radius	Vacuum in HG.	Weight Per Ft.
671-3010	XFR100	1"	1.46"	150 psi	2.8"	26"	0.57-lbs
671-3015	XFR150	1.5"	2.00"	150 psi	3.2"	26"	0.75-lbs
671-3020	XFR200	2"	2.52"	150 psi	3.9"	26"	0.99-lbs
671-3030	XFR300	3"	3.62"	150 psi	5.9"	26"	1.68-lbs

SSW *Saint Gobain Softwall Discharge Hose*



Tube: White Chlorobutyl
Cover: Blue EPDM
Reinforcement: Two fabric spirals
Color: Blue
Temp. Range: -40° to 225°F
Max. Length: 100'
Approvals: 3-A, FDA, USDA

Lightweight and easy to maneuver hose, suitable for straight discharge applications. Ideal for overhead CIP wash units, as the super smooth seamless tube will not impart taste or odor and handles most CIP solutions with ease. Cover maintains a clean appearance and resists abrasion.

Stock #	Model	ID	OD	Working Pressure	Min. Bend Radius	Vacuum in HG.	Weight Per Ft.
671-2415	SSW150	1.5"	2.16"	250 psi	-	-	1-lb
671-2420	SSW200	2"	2.66"	250 psi	-	-	1.25-lbs
671-2425	SSW250	2.5"	3.19"	250 psi	-	-	1.66-lbs
671-2430	SSW300	3"	3.75"	250 psi	-	-	2.23-lbs

*3-A 62-02 standard applies only to assemblies of 3/4" diameter and larger.

WARNING: Working pressure ratings are based on ambient temperature. Working pressure and vacuum ratings will decrease as temperatures increase.

Rubber Hose

GCR Saint Gobain Crush Resistant Hose



Tube:	White Santoprene™ Rubber
Cover:	Red EDPM w/ White Stripe
Reinforcement:	Multiple fabric spirals w/ monofilament helix
Color:	Red
Temp. Range:	-40° to 225°F
Max. Length:	100'
Approvals:	3-A, FDA, USDA

Transports a wide variety of dairy and food products—suited especially for receiving bay or raw product intake applications, as the seamless tube will not impart taste or odor. Slightly heavier and less flexible than our suction and discharge hose, the crush resistant hose has a high working pressure to deliver your products safely and effectively. *Caution: GCR is rated at 20" Hg (about 75% vacuum) but will actually pull a full vacuum when new. However, repeated collapsing of the hose will create a "soft spot" that reduces vacuum capabilities, even though it rebounds to its original shape.*

Stock #	Model	ID	OD	Working Pressure	Min. Bend Radius	Vacuum in HG.	Weight Per Ft.
671-2615	GCR150	1.5"	2.16"	250 psi	5.0"	20"	1.05-lbs
671-2620	GCR200	2"	2.66"	250 psi	7.0"	20"	1.33-lbs
671-2625	GCR250	2.5"	3.19"	250 psi	12.0"	20"	1.77-lbs
671-2630	GCR300	3"	3.75"	250 psi	18.0"	20"	2.3-lbs
671-2640	GCR400	4"	4.75"	250 psi	36.0"	20"	2.94-lbs

MHH Saint Gobain Suction & Discharge Hose



Tube:	White Chlorobutyl
Cover:	White Natural Rubber w/ Black & White Pattern stripe
Reinforcement:	Two fabric plies w/ double wire helix
Color:	White
Temp. Range:	-40° to 190°F continuous
Max. Length:	100'
Approvals:	3-A, FDA, USDA

Specifically designed to handle applications involving the transportation of milk. The durable inner and outer material offer added protection against extreme temperatures that are associated with milk hauling.

Stock #	Model	ID	OD	Working Pressure	Min. Bend Radius	Vacuum in HG.	Weight Per Ft.
671-2020	MHH51	2"	2.57"	90 psi	5.0"	29"	1.35-lbs
671-2025	MHH63	2.5"	2.99"	90 psi	7.0"	29"	1.68-lbs
671-2030	MHH76	3"	3.52"	90 psi	14.0"	29"	2-lbs

BRH Saint Gobain Brewer Hose



Tube:	White Chlorobutyl
Cover:	Red EPDM
Reinforcement:	1" and 1.5" have 4-ply fabric reinforcement, 2" and 3" have 6-ply fabric reinforcement
Color:	Red
Temp. Range:	-22° to 222°F
Max. Length:	100'
Approvals:	3-A, FDA, USDA

Specially designed to meet the needs of the brewing industry. An excellent choice for transfer of non-oily liquid products, as it resists damage from kinking or flattening. Available in bulk or fabricated hose assemblies.

Stock #	Model	ID	OD	Working Pressure	Min. Bend Radius	Vacuum in HG.	Weight Per Ft.
671-2516	HOSBRH16	1"	1.71"	250 psi	4.0"	20"	0.80-lbs
671-2524	HOSBRH24	1.5"	2.21"	250 psi	5.5"	20"	1.20-lbs
671-2532	HOSBRH32	2"	2.71"	250 psi	6.5"	20"	1.80-lbs
671-2548	HOSBRH48	3"	4.14"	250 psi	10.0"	20"	3.50-lbs

*3-A 62-02 standard applies only to assemblies of ¾" diameter and larger.

WARNING: Working pressure ratings are based on ambient temperature. Working pressure and vacuum ratings will decrease as temperatures increase.

Silicone Hose

SPD *Saint Gobain Single Ply Discharge Hose*



Tube: Platinum Cured Silicone
Cover: White Translucent
Reinforcement: Single ply polyester braid
Color: White Translucent
Temp. Range: -80° to 350°F
Max Length: SPD037 to SPD075: 100'
 SPD025, SPD100, and SPD150: 50'
Approvals: 3-A*, FDA, USP Class IV Silicone

Capable of transporting a variety of food and beverage applications as well as CIP and SIP cleaning where no vacuum rating is required. Sterilizable and autoclavable.

Stock #	Model	ID	OD	Working Pressure	Min. Bend Radius	Vacuum in HG.	Weight Per Ft.
671-2702	SPD025	0.25"	0.50"	155 psi	1.5"	-	0.10-lbs
671-2703	SPD037	0.375"	0.66"	125 psi	2.0"	-	0.14-lbs
671-2705	SPD050	0.5"	0.84"	105 psi	2.5"	-	0.19-lbs
671-2706	SPD062	0.625"	0.94"	90 psi	3.0"	-	0.25-lbs
671-2707	SPD075	0.75"	1.13"	65 psi	3.5"	-	0.30-lbs
671-2710	SPD100	1"	1.38"	55 psi	5.0"	-	0.40-lbs
671-2711	SPD150	1.5"	1.84"	45 psi	6.0"	-	0.58-lbs

FPD *Saint Gobain Four Ply Discharge Hose*



Tube: Platinum Cured Silicone
Cover: White Translucent
Reinforcement: Four ply polyester braid
Color: White Translucent
Temp. Range: -80° to 350°F
Max Length: 12'
Approvals: 3-A*, FDA, USP Class IV Silicone

Specifically designed for CIP and SIP cleaning thanks to the tough inner lining that is able to handle high pressures and won't impart taste or odor onto your products. Sterilizable and autoclavable.

Stock #	Model	ID	OD	Working Pressure	Min. Bend Radius	Vacuum in HG.	Weight Per Ft.
671-2712	FPD050	0.5"	0.91"	140 psi	8.0"	-	0.23-lbs
671-2713	FPD075	0.75"	1.16"	125 psi	10.0"	-	0.30-lbs
671-2714	FPD100	1"	1.41"	110 psi	12.0"	-	0.38-lbs
671-2715	FPD150	1.5"	1.91"	100 psi	-	-	0.52-lbs
671-2720	FPD200	2"	2.41"	100 psi	-	-	0.73-lbs
671-2730	FPD300	3"	3.41"	50 psi	-	-	0.95-lbs

FPW *Saint Gobain Wire Reinforced Hose*



Tube: Platinum Cured Silicone
Cover: White Translucent
Reinforcement: Four ply, polyester fabric w/ 316L stainless steel wire helix
Color: White Translucent
Temp. Range: -80° to 350°F
Max Length: 12'
Approvals: 3-A*, FDA, USP Class IV Silicone

Designed to be used in situations that require a silicone hose that can resist high temperatures and pressures. Won't impart taste or odor, and is suitable for CIP and SIP cleaning. Sterilizable and autoclavable.

Stock #	Model	ID	OD	Working Pressure	Min. Bend Radius	Vacuum in HG.	Weight Per Ft.
671-2750	FPW050	0.5"	0.91"	200 psi	2.5"	29"	0.28-lbs
671-2755	FPW075	0.75"	1.16"	200 psi	3.5"	29"	0.30-lbs
671-2760	FPW100	1"	1.41"	200 psi	5.0"	29"	0.44-lbs
671-2765	FPW150	1.5"	1.91"	200 psi	8.0"	29"	0.58-lbs
671-2770	FPW200	2"	2.41"	175 psi	11.0"	29"	0.88-lbs
671-2775	FPW250	2.5"	2.91"	175 psi	13.0"	29"	1.10-lbs
671-2780	FPW300	3"	3.41"	150 psi	17.0"	29"	1.57-lbs

*3-A 62-02 standard applies only to assemblies of 3/4" diameter and larger.

WARNING: Working pressure ratings are based on ambient temperature. Working pressure and vacuum ratings will decrease as temperatures increase.

PVC Hose

CSC Saint Gobain Clear Helix Hose



Tube: PVC
Reinforcement: Rigid Clear PVC Helix
Color: Clear
Temp. Range: -4° to 150°F
Max. Length: 100'
Approvals: 3-A, FDA, USDA

Ideal for transporting potable water, beer, wine, juice, milk, and other dairy products. For very cold applications, we recommend our MLT or MHH hose.

Stock #	Model	ID	OD	Working Pressure	Min. Bend Radius	Vacuum in HG.	Weight Per Ft.
671-2210	CSC100	1"	1.22"	95 psi	4.0"	29"	0.23-lbs
671-2215	CSC150	1.5"	1.81"	80 psi	5.0"	29"	0.41-lbs
671-2220	CSC200	2"	2.34"	80 psi	7.0"	29"	0.67-lbs
671-2225	CSC250	2.5"	2.94"	60 psi	10.0"	28"	0.85-lbs
671-2230	CSC300	3"	3.44"	55 psi	11.0"	28"	1.36-lbs
671-2240	CSC400	4"	4.53"	50 psi	19.0"	28"	1.91-lbs

CSW Saint Gobain White Helix Hose



Tube: PVC
Reinforcement: Rigid White PVC Helix
Color: Transparent
Temp. Range: -4° to 150°F
Max. Length: 100'
Approvals: 3-A, FDA, USDA

Designed for transporting potable water, beer, wine, juice, milk, and other dairy products. For very cold applications, we recommend our MLT or MHH hose.

Stock #	Model	ID	OD	Working Pressure	Min. Bend Radius	Vacuum in HG.	Weight Per Ft.
671-2310	CSW100	1"	1.22"	95 psi	4.0"	29"	0.23-lbs
671-2315	CSW150	1.5"	1.81"	80 psi	5.0"	29"	0.41-lbs
671-2320	CSW200	2"	2.34"	80 psi	7.0"	29"	0.67-lbs
671-2325	CSW250	2.5"	2.94"	60 psi	10.0"	28"	0.85-lbs
671-2330	CSW300	3"	3.44"	55 psi	11.0"	28"	1.36-lbs

MLT Tigerflex® Suction & Discharge Hose



Tube: PVC
Reinforcement: Rigid White PVC Helix
Color: Transparent
Temp. Range: -40° to 150°F
Max. Length: 100'
Approvals: 3-A, FDA, USDA

Suited for cold applications due to the flexible frame that is able to resist extreme temperatures more easily. The food grade clear PVC hose with white helix features a smooth bore and cover to facilitate unrestricted flow and ease of cleaning.

Stock #	Model	ID	OD	Working Pressure	Min. Bend Radius	Vacuum in HG.	Weight Per Ft.
370-2020	MLT200	2"	2.33"	75 psi	5.0"	28"	0.65-lbs
370-2025	MLT250	2.5"	2.87"	55 psi	8.0"	28"	0.84-lbs
370-2030	MLT300	3"	3.42"	55 psi	10.0"	28"	1.20-lbs

*3-A 62-02 standard applies only to assemblies of 3/4" diameter and larger.

WARNING: Working pressure ratings are based on ambient temperature. Working pressure and vacuum ratings will decrease as temperatures increase.

PVC Tubing

CSS Wire Helix Tubing



Tube: PVC
Reinforcement: Clear Extrusion w/ Steel Wire Helix
Color: Clear
Temp. Range: 25° to 150°F
Max. Length: CSS050 to CSS100: 100'
 CSS150 to CSS300: 50'
Approvals: 3-A*, FDA, USDA, USP Class VI Standards

Heavy-duty clear PVC tubing features a steel wire reinforcement which helps prevent kinking and collapsing. This tubing is suitable for milk handling and food processing applications.

Stock #	Model	ID	OD	Working Pressure	Min. Bend Radius	Vacuum in HG.	Weight Per Ft.
671-2105	CSS050	0.5"	0.81"	150 psi	2.0"	29"	0.21-lbs
671-2107	CSS075	0.75"	1.13"	150 psi	3.0"	29"	0.36-lbs
671-2110	CSS100	1"	1.38"	100 psi	4.0"	29"	0.44-lbs
671-2115	CSS150	1.5"	1.91"	50 psi	6.0"	29"	0.58-lbs
671-2120	CSS200	2"	2.50"	50 psi	8.0"	29"	0.84-lbs
671-2125	CSS250	2.5"	3.00"	50 psi	10.0"	29"	1.38-lbs
671-2130	CSS300	3"	3.50"	50 psi	12.0"	29"	1.62-lbs

CBT Braid Reinforced Tubing



Tube: PVC
Reinforcement: Extrusion w/ Polyester Textile Inner Braid
Color: Clear
Temp. Range: 25° to 150°F
Max. Length: CBT050 to CBT100: 100'
 CBT150 and CBT200: 50'
Approvals: 3-A*, FDA, USDA, USP Class VI Standards

Flexible, clear tubing reinforced with multiple polyester braids is suitable for a wide variety of food and beverage applications.

Stock #	Model	ID	OD	Working Pressure	Min. Bend Radius	Vacuum in HG.	Weight Per Ft.
671-2805	CBT050	0.5"	0.81"	250 psi	4.0"	-	0.17-lbs
671-2807	CBT075	0.75"	1.13"	200 psi	5.0"	-	0.30-lbs
671-2810	CBT100	1"	1.38"	150 psi	6.0"	-	0.38-lbs
671-2815	CBT150	1.5"	1.91"	100 psi	8.0"	-	0.64-lbs
671-2820	CBT200	2"	2.50"	75 psi	12.0"	-	0.94-lbs

CCT Clear Tubing



Tube: PVC
Reinforcement: Clear Extrusion—No Reinforcement
Color: Clear
Temp. Range: 25° to 150°F
Max. Length: CCT050 to CCT100: 100'
 CCT150 and CCT200: 50'
Approvals: 3-A*, FDA, USDA, USP Class VI Standards

Heavy-duty clear PVC tubing features a steel wire reinforcement which helps prevent kinking and collapsing. This tubing is suitable for milk handling and food processing applications.

Stock #	Model	ID	OD	Working Pressure	Min. Bend Radius	Vacuum in HG.	Weight Per Ft.
671-2850	CCT050	0.5"	0.81"	45 psi	4.5"	-	0.13-lbs
671-2875	CCT075	0.75"	1.13"	40 psi	5.5"	-	0.30-lbs
671-2880	CCT100	1"	1.38"	35 psi	9.0"	-	0.38-lbs
671-2885	CCT150	1.5"	1.91"	35 psi	15.0"	-	0.54-lbs
671-2890	CCT200	2"	2.50"	35 psi	18.0"	-	0.96-lbs

*3-A 62-02 standard applies only to assemblies of 3/4" diameter and larger.

WARNING: Working pressure ratings are based on ambient temperature. Working pressure and vacuum ratings will decrease as temperatures increase.

How to Order Sanitary Hose Assemblies

Build Your Assembly Part Number



PSD		200	RE	200 TC	200 TC	P	180 (inches)
Hose		ID Size	ReSeal®	Size First End Connection	Size Second End Connection	Hose Sleeve Material	Assembly Length Inches
Rubber		Size Code	Coupler Style	End Connection		Hose Sleeve	Assembly Length
PSD	Gray Suction & Discharge	025 = 1/4"	RE = Reusable	TC = Sanitary Clamp		S = Stainless	Inches
PSDW	White Suction & Discharge	037 = 3/8"		BS = Bevel Seat with Hex Nut		P = Polymer	
GCR	Red Crush Resistant	050 = 1/2"		BT = Bevel Male Thread			
SSW	Softwall Discharge	062 = 5/8"		IF = Female I-Line			
MHH	MilkFlex	075 = 3/4"		IM = Male I-Line			
BRH	Red Brewer	100 = 1"		JP = John Perry with Hex Nut			
PVC		150 = 1-1/2"		JT = John Perry Male Thread			
CSC	Clear Helix	200 = 2"		MT = Male Pipe Thread			
CSW	White Helix	250 = 2-1/2"		TE = Tube End (Butt Weld)			
MLT	White Helix—Low Temp	300 = 3"		DF = Cam & Groove Female			
CCT	Clear Tubing	400 = 4"		AM = Cam & Groove Male			
CBT	Braided Tubing	600 = 6"		AF = Flange			
CSS	Wire Helix			QL = Q-Line			
Silicone							
SPD	Single Ply Discharge						
FPD	Four Ply Discharge						
FPW	Wire Helix Suction & Discharge						

Overall length tolerances for assemblies are:

- 1/4" on assemblies to 24"
- 1/2" on assemblies 25" to 60"
- 1% on assemblies over 60"

Build Your Custom Assembly in Just 7 Easy Steps:

- 1 Select code for hose style
- 2 Specify hose ID
- 3 Coupler style
RE = reusable
- 4 & 5 Specify size and connection of each end fitting
- 6 Select hose sleeve material
Stainless or Polymer
- 7 Specify overall assembly length

Need help?
We can recommend the right hose for your application!
Call our hose specialists for assistance.

*3-A 62-02 standard applies only to assemblies of 3/4" diameter and larger.

WARNING: Working pressure ratings are based on ambient temperature. Working pressure and vacuum ratings will decrease as temperatures increase.

Hose Supports



HoseGard™ Hose Supports

Provide protection that helps increase the service life of your hose. The durable HDPE construction resists damage from chemical, washdown or harsh environments, while the lightweight, two-piece design with stainless steel socket head cap screws installs easily on your hose, stays in place and allows the hose to slide across the floor. The built-in handle facilitates movement, placement and carrying of the hose, while protecting workers from ergonomic-related injuries and associated costs. Designed for use on rubber hoses. Compliant with FDA 21 CFR 177.1520. Stock color is blue but also available in yellow. **To be used with Saint Gobain hoses only.**

Stock #	Fits Hose	Support OD Diameter	Unit
673-1150	1.5"ID x 2-5/32"OD	9"OD	EA
673-1200	2"ID x 2-21/32"OD	9"OD	EA
673-1250	2.5"ID x 3-3/16"OD	9"OD	EA
673-1300	3"ID x 3-3/4"OD	9"OD	EA
673-1400	4"ID x 4-3/4"OD	9"OD	EA



White Hose Supports

Keep hoses off the ground, allowing them to remain clean, reduce wear and tear on cover, and prevent damage to end connections with hose supports. Ultra-high molecular weight (UHMW) polyethylene material allows hose assemblies to slide freely while being moved. Extremely durable and little or no water absorption. Stainless steel screws and nuts are counter-sunk into the UHMW. Larger sizes available with 1" lip to increase stability. White.

Stock #	Fits Hose	Support OD Diameter	Unit
Hose Supports			
692-2431	1-1/2"ID x 2-5/32"OD	5"OD	EA
692-2432	2"ID x 2-21/32"OD	5-1/2"OD	EA
692-2433	2-1/2"ID x 3-6/32"OD	6"OD	EA
692-2434	3"ID x 3-24/32"OD	7"OD	EA
692-2435	4"ID x 4-24/32"OD	8-1/2"OD	EA
Hose Supports with 1" Lip			
692-2441	2-1/2"ID x 3-6/32"OD	6"OD	EA
692-2442	3"ID x 3-24/32"OD	7"OD	EA
692-2443	4"ID x 4-24/32"OD	8-1/2"OD	EA

Hose Terminology

Term	Definition
I.D.	Inside diameter of the hose tube.
O.D.	Outside diameter of the hose tube.
Working Pressure	The maximum recommended pressure at which to use the hose on a continuous basis.
Min. Bend Radius	An expression of how much a hose can be uniformly bent without being kinked or damaged. Measured to the innermost surface (except metal hose which is measured from the center radius).
Vacuum HG	Inches of mercury unit of measurement for pressure and is used to measure vacuum.
Tube	The innermost part of the hose—its material must be compatible with the product flowing through it. Handling food products, the tube must be made of materials which comply with FDA regulations, USDA and 3-A may also apply.
Reinforcement	Fabric plies, yarn, or wire braided material between hose tube and cover. Enables the tube to withstand pressure or, in a suction hose, resist collapse. Helps prevent kinking and, in some hoses, metal reinforcement helps prevent explosions by grounding electrostatic charges.
Cover	The outermost part of the hose. Protects tube and reinforcement from abrasions, cuts, weathering, and chemical action. Animal fat also degrades hose covers.
Temp. Range	Temperature range of products and cleaning chemicals going through the inside of the hose.
Helix	A stiff wire or plastic rod spiraled around the tube to provide suction or vacuum capability and also helps prevent kinking.
Hose Length	Length from fitting end to fitting end.

Sanitary Clamp Sizing Information

These actual-size drawings are provided for your convenience and ordering accuracy when specifying sanitary fittings.

- 0.984" OD is the same for 1/2", 3/4" ID styles.
- 1.984" OD is the same for 1" and 1 1/2" ID styles.
- Varying OD for the 2", 2 1/2" and 4" ID styles.

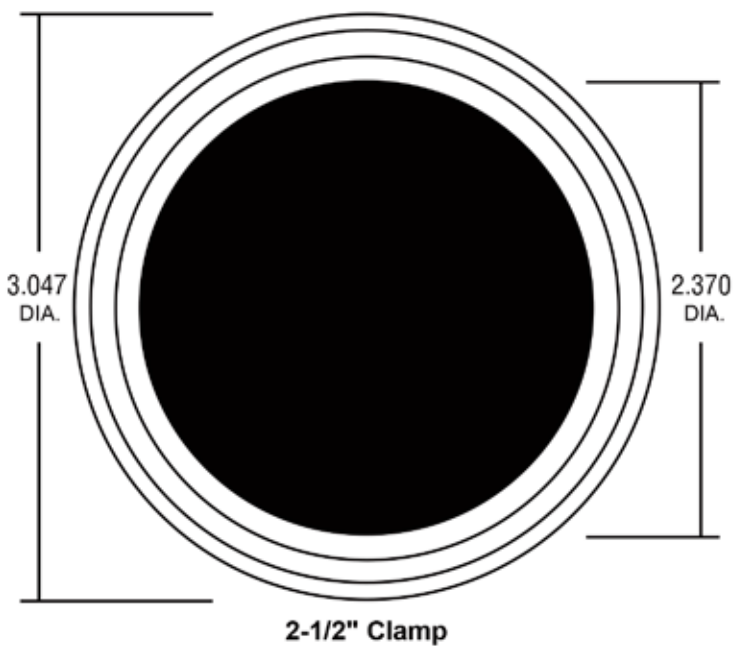
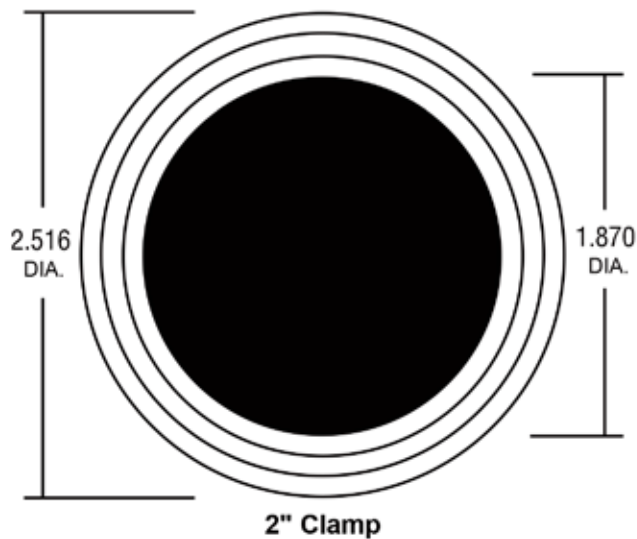
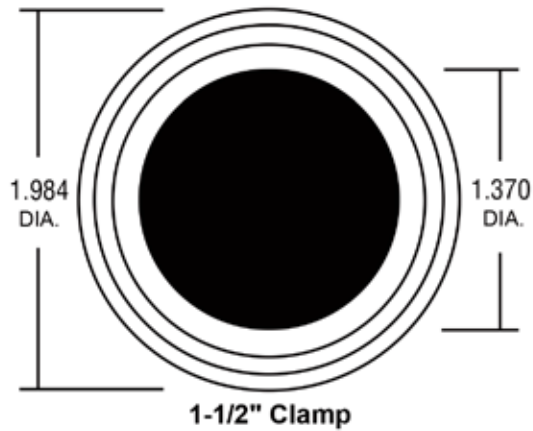
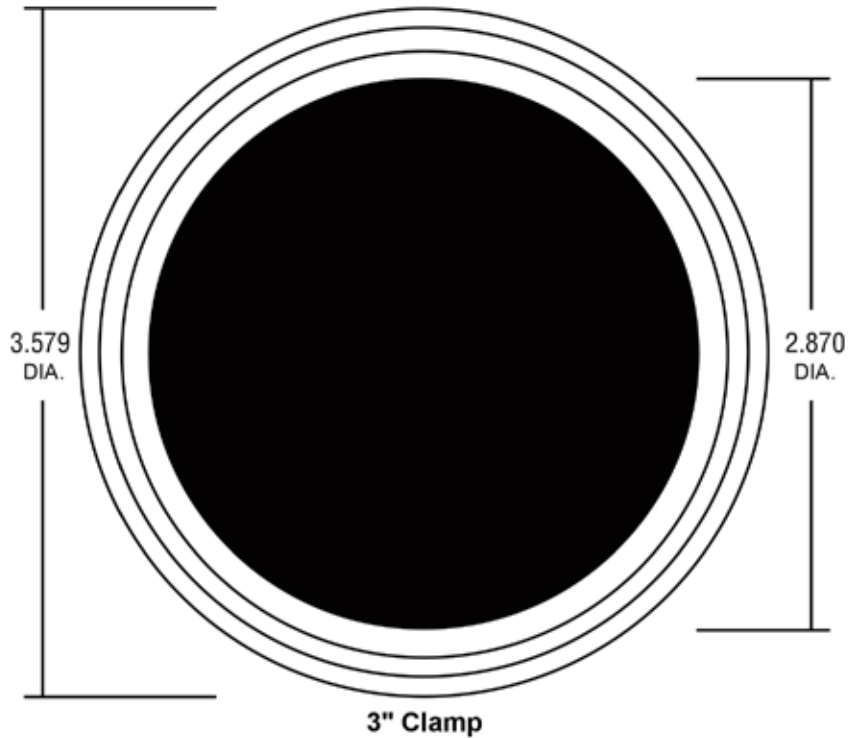
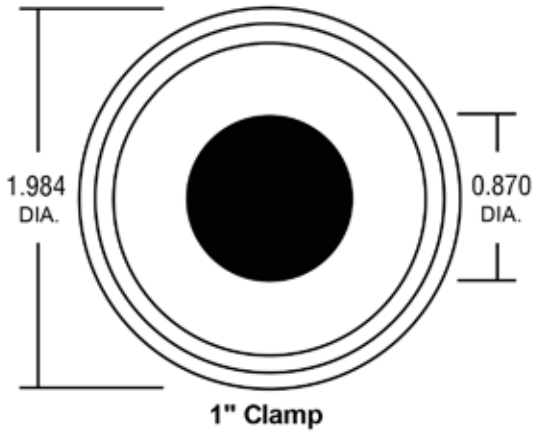
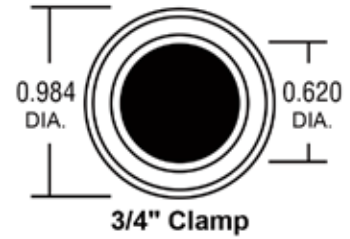
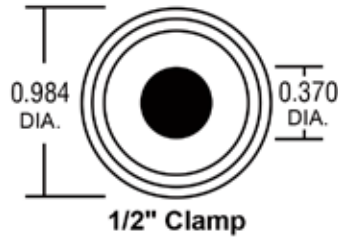

What's Inside

Seal-Rite™

Permanent Crimp3-14

ReSeal®

Reusable Coupler15-21

Hose Supports22



Hose Terminology22

Fitting Sizing Chart23

Nelson-Jameson—Your Complete Source for Sanitary Hose Assemblies

Our deep knowledge of the food, dairy, and beverage industry, combined with our strong partnerships with leading sanitary hose manufacturers, means that we have the expertise and resources to meet your unique needs.

We offer:

-  Custom sizing of 3-A hose assemblies
-  Large selection of in stock sanitary hose
-  Expertise in sanitary hose products and hose assemblies
-  Competitive pricing
-  Quick availability of customized products



NJ803-23