

# Operating Instructions

## ProMinent® Backpressure and Pressure Relief Valves

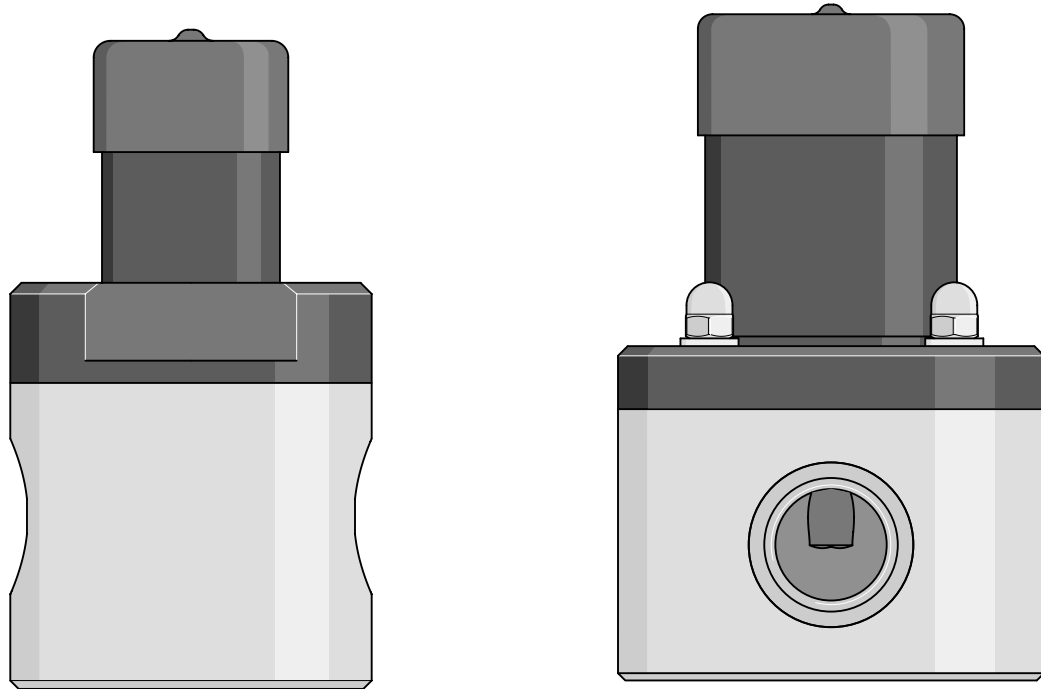

<i>Contents</i>	<i>Page</i>	<i>Contents</i>	<i>Page</i>
Safety Instructions .....	2	Optional Diaphragm Safety Port .....	6
Unpacking .....	2	Part Numbers & Accessories .....	8
Introduction .....	2	Maintenance .....	7
Installation .....	3	Spare Parts .....	7
Description of Controls & Operation .....	5	Repair Service .....	7
Helpful Tips .....	5	Troubleshooting .....	7
Specifications .....	5	Dimensions .....	11

**Read the operating instructions before installation and use. The warranty does not cover damages due to faulty operation. Keep for reference and replacement information.**

BA B/PRVI 01 1/04 NA      Order no.7750089

**ProMinent Fluid Controls, Inc.**  
 136 Industry Drive, Pittsburgh, PA 15275-1014  
**ProMinent Fluid Controls Ltd.**  
 490 Southgate Drive, Guelph, Ontario N1G 4P5

*e-mail: sales@prominent.cc*  
 Phone: 412/787-2484    Telefax: 412/787-0704  
*e-mail: sales@prominent.ca*  
 Phone: 519/836-5692    Telefax: 519/836-5226

# Operating Instructions for ProMinent® Backpressure and Pressure Relief Valves

## *General Safety Considerations*

### **SAFETY INSTRUCTIONS**

- Wear protective clothing and glasses when working with or near chemicals.
- Refer to the MSDS for all chemicals being used.
- Use only ProMinent® parts. Use of other parts may result in damage to equipment or injury.
- Flush all components that are in contact with chemicals prior to servicing.
- Secure all chemicals and equipment making them inaccessible to children and pets.
- Dispose of all chemicals and waste according to all local, state and federal regulations.
- Stop the flow of sample through the system prior to working on the pump.
- Do not exceed the maximum operating pressure.

## *Safety Operating Procedures*

### **UNPACKING**

CHECK ALL EQUIPMENT FOR DAMAGE AND FOR COMPLETENESS AGAINST THE ORDER. REPORT INCORRECT ORDERS OR DAMAGES TO THE SELLER IMMEDIATELY.

The carton should contain:

1 Backpressure or Pressure Relief Valve as ordered  
Accessories as ordered

### **INTRODUCTION**

ProMinent® diaphragm pressure relief valves are designed to protect chemical feed systems from overpressure caused by defective equipment or by blockage in the chemical line. Chemical flows through the valve via an internal chamber. When the pressure in the chemical line exceeds the preset pressure of the valve, the diaphragm lifts off the seat and the chemical then flows out the bottom port back into the chemical tank. The relief pressure is adjustable from 0-150 psig by the adjuster in the top of the valve.

ProMinent® diaphragm backpressure valves are used to enhance the performance of the chemical feed pumps by providing a constant head pressure. These valves can also be used as an antisiphon valve. The diaphragm is held against the seat by an internal spring. The backpressure is adjustable from 0-150 psig. When the inlet pressure exceeds the preset pressure, the diaphragm lifts off the seat and the chemical flows to the injection point.

## FUNCTION AND DESCRIPTION

The ProMinent® backpressure and pressure relief valves have been modified to include an optional diaphragm safety port to route the chemical in the event of a diaphragm failure. The optional diaphragm safety port fitting must be removed to adjust the backpressure screw. **NOTE: If the optional diaphragm safety port tubing adapter is not installed, upon diaphragm failure, chemical will come out thru the screwdriver adjustment slot.**



## INSTALLATION

### Pressure Relief Valve

Install as close to the chemical pump discharge valve as possible, without any other equipment, especially shut-off valves, between the pressure relief valve and the pump.

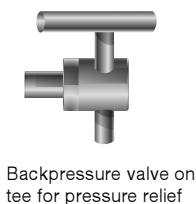

The relief port in the bottom of the valve should be vented back to the chemical tank or directly to the drain. No backpressure can be applied to the outlet of the valve. This will impair the valve's ability to relieve at the preset pressure. The valve should not be installed across the pump. That is, the valve should not be connected from the discharge of the pump to the suction side of the pump if there is a check valve in the suction line that could prevent pressure relief.

### Back Pressure Valve

The backpressure valve can be installed anywhere in the discharge line, provided there is some downstream pressure at the dosage point via an injection valve or line pressure. If there is no downstream pressure, the backpressure valve should be installed at the dosage point to prevent drainage of the chemical line. The chemical must flow across the valve, in the direction of the arrow.

The performance of the backpressure valve will be enhanced with the installation of a pulsation dampener to smooth out the discharge/ suction cycles of the pump.

The pulsation dampener should be sized for the dosage volume of the pump head. For most applications, dampeners without diaphragms are acceptable. However some applications require dampeners with diaphragms.

### Typical Installation

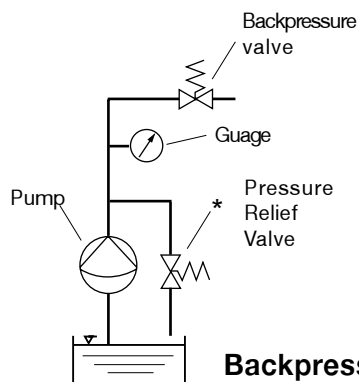

**Backpressure valve to produce a constant pressure to pump against.**

**Backpressure valve in conjunction with a pulsation dampener.**

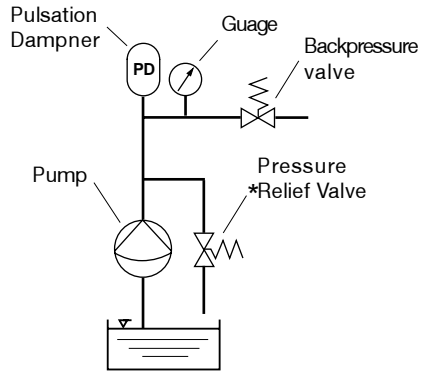

**Backpressure valve used when the suction pressure is high.**

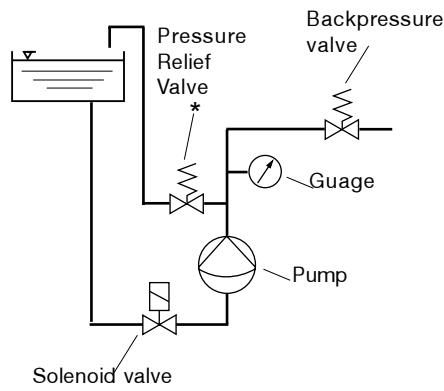

**Pressure relief valve to protect pump from overpressure**

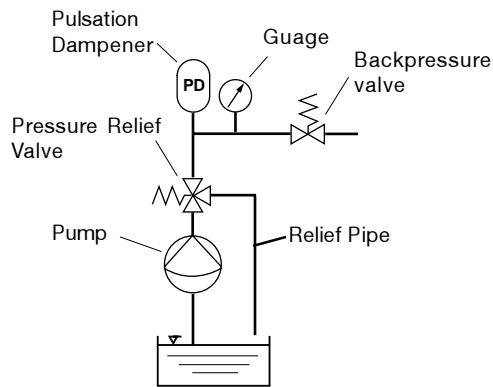



## DESCRIPTION OF CONTROLS AND OPERATION

Adjust the backpressure and the pressure relief valves by turning the pressure adjuster on the valves to the desired pressure. The valves have a screwdriver slot to adjust the pressure. Turning clockwise increases the pressure and counterclockwise decreases the pressure.

**OR:**

## ADJUSTING THE PRESSURE ON THE VALVES

Remove the optional diaphragm safety port from the top of the valve by unscrewing it from the backpressure/pressure relief valve. The valves have a screwdriver slot to adjust the pressure. Turning clockwise increases the pressure and counterclockwise decreases the pressure. Replace the relief assembly by screwing it onto the backpressure/pressure relief valve.

## HELPFUL TIPS

1L = 0.264 gallon

1000 mL = 1 L

1 bar = 14.5 psig

## SPECIFICATIONS

Size:	1/4", 1/2", 3/4", 1", 1 1/2", 2" NPT or Socket
Diaphragm material:	PTFE-faced EPDM
Liquid handling materials:	PP, PVC, PTFE, PVDF, 316 Stainless Steel
Pressure adjustments:	0-150 psig
Flow rates at 45 psig:	1/4" - 132 gph 1/2" - 132 gph 3/4" - 235 gph 1" - 345 gph 1-1/2" - 740 gph 2" - 740 gph
Max. Temperature:	PP - 122°F PVC - 100°F PTFE - 250°F PVDF - 250°F 316 Stainless - 250°F

**ATTACHING TUBING TO THE OPTIONAL DIAPHRAGM SAFETY PORT**

Connector sets connect flexible tubing of different sizes to optional diaphragm safety port fitting. A connector set consists of hose nozzle, grip ring, union nut and gasket. All connector sets fit on optional diaphragm safety port with M20 X 1.5 threads. Part number includes two connector sets. One of the following conector sets are required to attach the tubing to the relief port:

**PART NUMBERS**

PP/VITON® for tubing size 1/4" x 3/16" .....	790872
PP/VITON® for tubing size 1/2" x 3/8" .....	740133
PP/EPDM for tubing size 1/4" x 3/16" .....	790885
PP/EPDM for tubing size 1/2" x 3/8" .....	740132
PP/EPDM for tubing size 1/4" x 1/2" .....	817163
PVC/VITON® for tubing size 1/4" x 3/16" .....	817050
PVC/VITON® for tubing size 1/2" x 3/8" .....	817055
PVC/VITON® for tubing size 1/4" x 1/2" .....	817068
PVC/EPDM for tubing size 1/4" x 3/16" .....	790871
PVC/EPDM for tubing size 1/2" x 3/8" .....	740160
PTFE for tubing size 1/4" x 3/16" .....	817201
PTFE for tubing size 1/2" x 3/8" .....	791199

Cut hose ends straight across

Push Union Nut (2) and clamping ring (3) onto tubing (1)

Push the tubing end (1) over the nozzle (4) to the stop.

Widen if necessary

Place the hose (1) with the nozzle (4) onto the optional diaphragm safety port fitting (6)

Tighten the union nut (2) while pressing in the tubing (1)

Pull the tubing connected to the optional diaphragm safety port fitting (6); then retighten the union nut

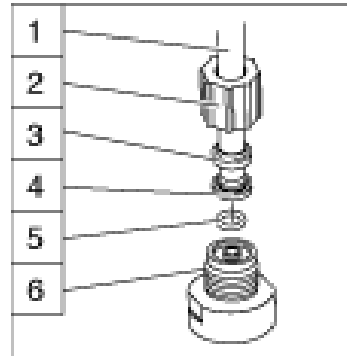

- 1     Tubing**
- 2     Union Nut**
- 3     Clamping Ring**
- 4     Nozzle**
- 5     O-ring**
- 6     Optional diaphragm safety port fitting**

## MAINTENANCE

Routinely look for leaks that could indicate a diaphragm rupture. Replacement of the diaphragm can be done without taking the valve out of the chemical line.

### Replacing the diaphragm

- Relieve the pressure from the system.
- Flush the chemical lines prior to disassembling the valve.
- Unscrew the pressure adjuster to relieve the pressure from the diaphragm.
- Unscrew the valve top from the valve bottom **or** Remove the 4 bolts from the top of the valve.
- Lift off the top of the valve.
- Inspect the diaphragm and replace as necessary.
- Inspect the adjustment spring for rust or corrosion and replace if necessary.
- Replace the spring and the spring bumper into the top of the valve.
- Slide the top of the valve back over the bolts and Tighten the screws **or** Screw the valve top to the valve bottom and tighten.
- Screw in the pressure adjuster to approximately the same position it was prior to disassembly.
- Use a pressure gauge to adjust the valve to the desired pressure setting.

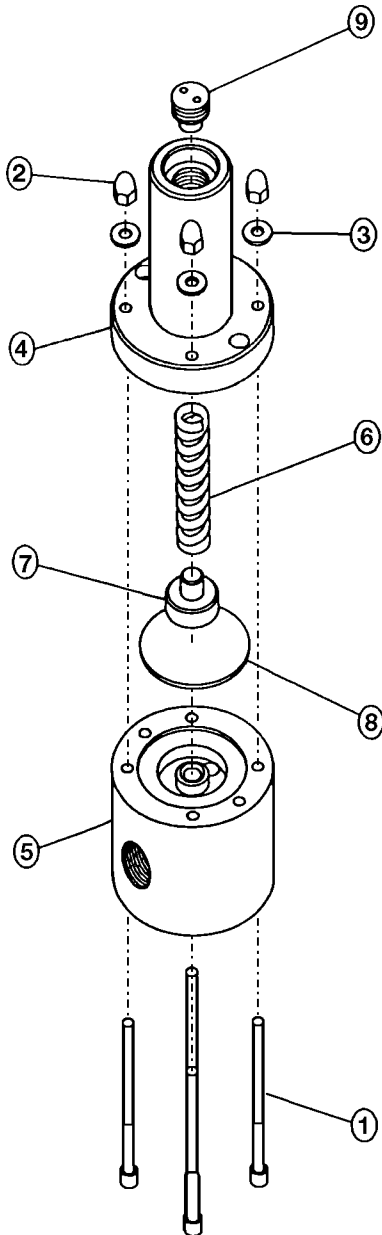

Example of a backpressure valve

## SPARE PARTS

1. Bolts
2. Hex Nut
3. 1/4" Flat Washer
4. Valve Lid
5. Valve Body
6. Pressure Spring
7. Spring Plate
8. Diaphragm
9. Pressure Adjustment Screw

## REPAIR SERVICE

Repairs must be done by ProMinent® Fluid Controls. Call your distributor or ProMinent® at (412) 787-2484 for a return goods authorization. **DO NOT** return any goods without authorization. All items must be free of hazardous chemicals and clean when returned.

## TROUBLESHOOTING

**Leaking:** Check for clogs, diaphragm ruptures or corrosion of the spring.

**Part Numbers and Accessories**

**1/4" FNPT Valves**

<u>Material</u>	<u>Backpressure Valve (2-port)</u>	<u>Pressure Relief Valve (3-port)</u>
PP	1009444	1009452
PVC	1009445	1009453
PVDF	1009446	1009454
316 SS	1009447	1009455

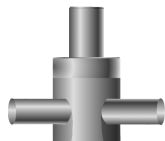

Backpressure Valve (2 port)

**Tubing Adapters**

(1 required per valve port): 1/4" x 3/16" tubing x 1/4" MNPT

PP/EPDM (PP1)	7358222
PP/Viton (PP2)	7358226
PVC/Viton (NP6)	7358223
PTFE (TT1)	7358224

**1/2" FNPT Valves**

<u>Material</u>	<u>Backpressure Valve (2-port)</u>	<u>Pressure Relief Valve (3-port)</u>
PP	1006846	1006858
PVC	1006850	1006862
PVDF	1006854	1006866
316 SS	1008796	1008800

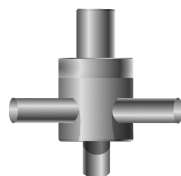

Pressure Relief Valve (3 port)

**Tubing Adapters**

(1 required per valve port): 1/2" x 3/8" tubing x 1/2" MNPT

PP/EPDM (PP1)	7358220
PP/Viton (PP2)	7358227
PVC/Viton (NP6)	7358221
PTFE (TT1)	7358225

**3/4" FNPT Valves**

<u>Material</u>	<u>Backpressure Valve (2-port)</u>	<u>Pressure Relief Valve (3-port)</u>
PP	1006847	1006959
PVC	1006851	1006863
PVDF	1006855	1006867
316 SS	1008797	1008801

**Part Numbers and Accessories (CONT.)**

**1" FNPT Valves**

<b>Material</b>	<b>Backpressure Valve (2-port)</b>	<b>Pressure Relief Valve (3-port)</b>
PP	1006848	1006860
PVC	1006852	1006864
PVDF	1006856	1006868
316 SS	1008798	1008802

**1-1/2" FNPT Valves**

<b>Material</b>	<b>Backpressure Valve (2-port)</b>	<b>Pressure Relief Valve (2-port)</b>
PP	1006849	1006865
PVC	1006853	1006865
PVDF	1006857	1006869
316 SS	1008799	1008803

**2" FNPT Valves**

<b>Material</b>	<b>Backpressure Valve (2-port)</b>	<b>Pressure Relief Valve (2-port)</b>
PP	1009448	1009456
PVC	1009449	1009457
PVDF	1009450	1009458
316 SS	1009451	1009459

**Spare Diaphragms**

1/4" - 1/2" valve PTFE/EPDM	1006813	1006813
3/4" - 1" valve PTFE/EPDM	1006814	1006814
1-1/2"-2" valve PTFE/EPDM	1006815	1006815

**Part Numbers and Accessories**

**1/4" Socket Valves**

<u>Material</u>	<u>Backpressure Valve (2-port)</u>	<u>Pressure Relief Valve (3-port)</u>
PVC	1019891	1019892
PVDF	1019893	1019894

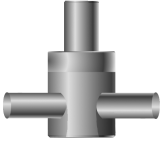

Backpressure Valve (2 port)

**1/2" Socket Valves**

<u>Material</u>	<u>Backpressure Valve (2-port)</u>	<u>Pressure Relief Valve (3-port)</u>
PVC	1019883	1019884
PVDF	1019895	1019896

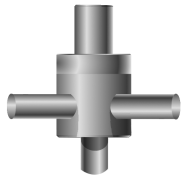

Pressure Relief Valve (3 port)

**3/4" Socket Valves**

<u>Material</u>	<u>Backpressure Valve (2-port)</u>	<u>Pressure Relief Valve (3-port)</u>
PVC	1019885	1019886
PVDF	1019897	1019898

**1" Socket Valves**

<u>Material</u>	<u>Backpressure Valve (2-port)</u>	<u>Pressure Relief Valve (3-port)</u>
PVC	1019887	1019888
PVDF	1019899	1019900

**1-1/2" Socket Valves**

<u>Material</u>	<u>Backpressure Valve (2-port)</u>	<u>Pressure Relief Valve (2-port)</u>
PVC	1019889	1019889
PVDF	1019901	1019901

**2" Socket Valves**

<u>Material</u>	<u>Backpressure Valve (2-port)</u>	<u>Pressure Relief Valve (2-port)</u>
PVC	1019891	1019891
PVDF	1019905	1019905

Dimensions

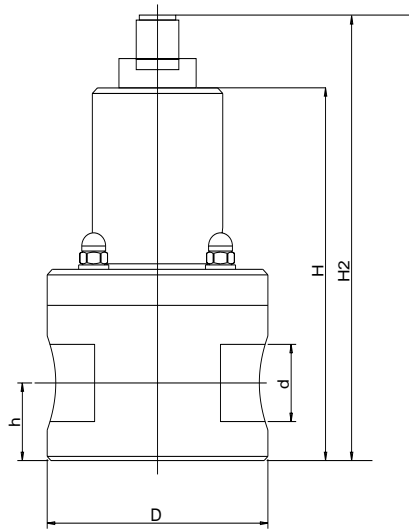

Valve size d [inches]	Thread type	h [mm]	h (in.)	D [mm]	D (in.)	H [mm]	H (in.)	H2 (mm)	H2 (in.)
1/4	NPT	31	1.2	65	2.6	125	4.9	158	6.2
1/2	NPT	31	1.2	65	2.6	125	4.9	158	6.2
3/4	NPT	28	1.1	88	3.5	136	5.4	169	6.7
1	NPT	36	1.4	98	3.9	145	5.7	178	7.0
1-1/2	NPT	56	2.2	118	4.6	229.5	9.0	260.5	10.3
2	NPT	56	2.2	118	4.6	229.5	9.0	260.5	10.3